

Installation Instructions

Surface Fixed

Congas
Page 1 of 2

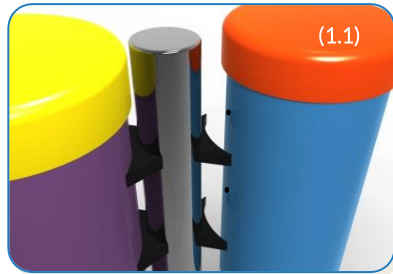

Weight of heaviest part **3.8kg** (Large drum Small Congas)
 Weight of heaviest part **4.5kg** (Large drum Medium Congas)
 Weight of heaviest part **5.2kg** (Large drum Large Congas)

1. Attach the steel leg to each of the congas with the M10x50 security screws, square washers and PU mounts. **(1.1)** (See Assembly Guide)

2. Attach Surface Fixing posts to legs **(1.2)** (See Ground Fix Post Installation Sheet)

3. **Locate Plate** in desired location and mark holes to fix to desired surface.

4. Fix to Surface using recommended ground anchors not supplied

5. Make sure all fixings are covered and secure using cover caps provided

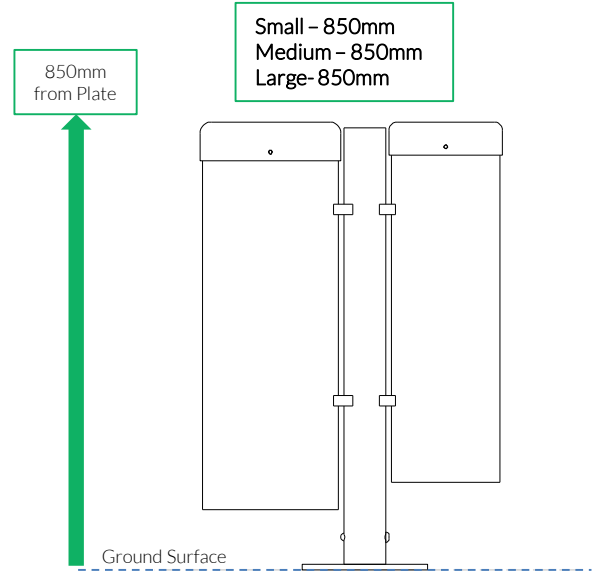
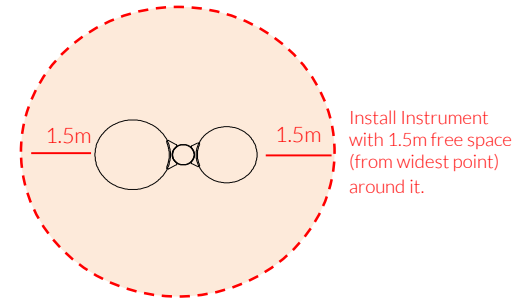

Instrument Components:



x4

M10x50 Security Screw



x4

M10x50x3 Square washer



x2

PU 200 Mount



x2

PU 250 Mount

Metric Conversion:
 178mm/ 7"
 850mm/ 33"
 1.5m/ 59"



Played with hands

Surface Fix Components:



x1

M10x70 Security Screw



x1

M10 Barrel Nut



x4

2 Part Cover Cap

Ground Anchors not supplied

Spares available from www.musical-play.com or from your local distributor

14.8 Kg
15 Kg
20 Kg

Assembly Guide PPCONG

Tools:
 x2
 TX 45 Driver Bit

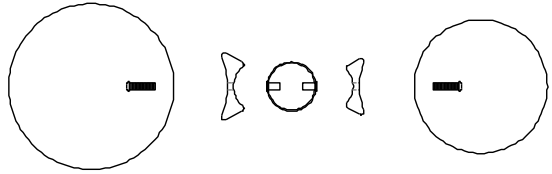
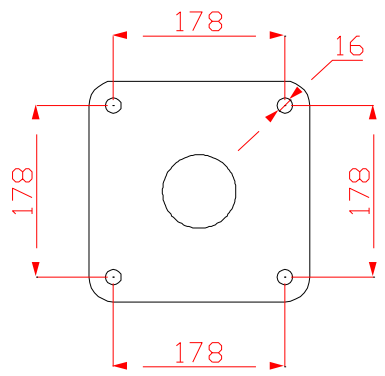

PPCONG PLAN

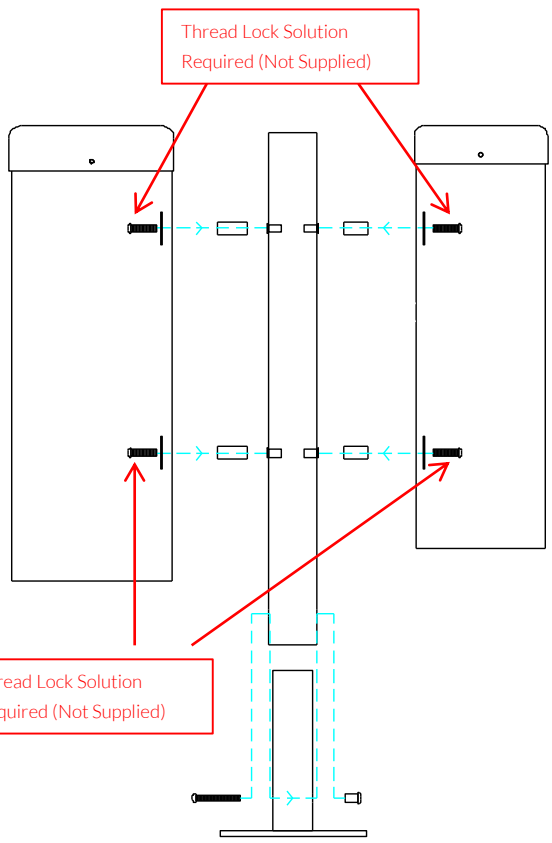



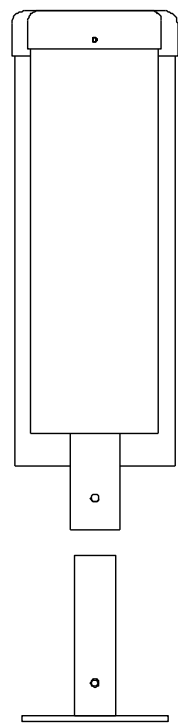



PPCONG FRONT



PPCONG SIDE

COMPONENTS LIST:





-  M10x50 Security Screw X4
-  M10x50x3 square washer X4
-  PU MOUNT 200 X2
-  PU MOUNT 250 X2
-  M10x70 Pin torx X1
-  M10 Barrel Nut Pin torx X1



Surface Fixed
 Congas
 Page 2 of 2



Instrument Components:

-  x4
M10x50 Security Screw
-  x4
M10x50x3 Square washer
-  x2
200 Mount
-  x2
250 Mount



Surface Fix Components:

-  x1
-  x1
-  x4

Ground Anchors
 not supplied

Spares available from
www.musical-play.com or
 from your local distributor

14.8 Kg
 15 Kg
 20 Kg

Installation Instructions

Surface Fixed

Duo
Page 1 of 3

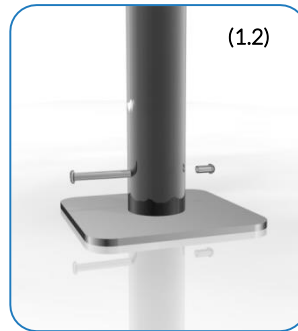
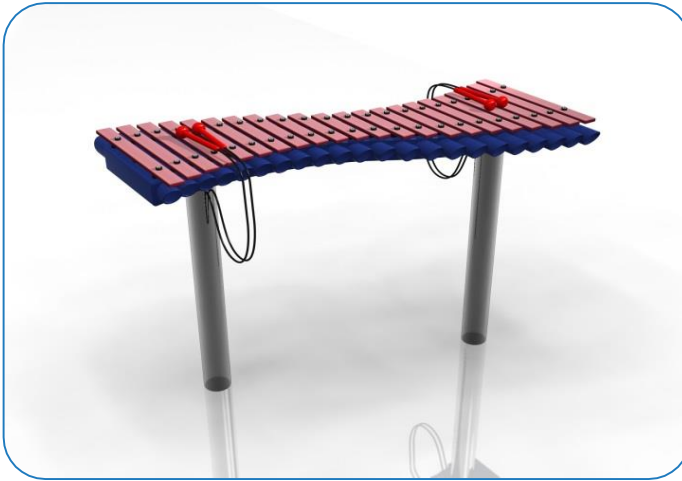

Weight of heaviest part **14kg** (Duo)

1. Attach the steel legs to the base of the instrument with the M8 Nyloc Nuts and 2 part security caps. **(1.1)** (See Assembly Guide)

2. Attach Surface Fixing posts to legs **(1.2)** (See Ground Fix Post Installation Sheet)

3. **Locate Plate** in desired location and mark holes to fix to desired surface.

4. Fix to Surface using recommended ground anchors not supplied

5. Make sure all fixings are covered and secure using cover caps provided

6. Attach the 1 pair of beater to the saddle strap on each leg. **(1.3)**

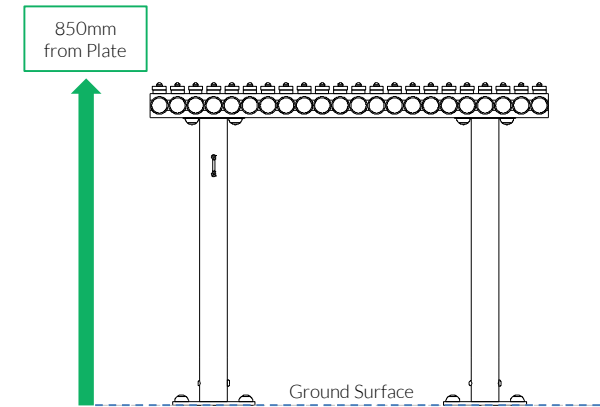
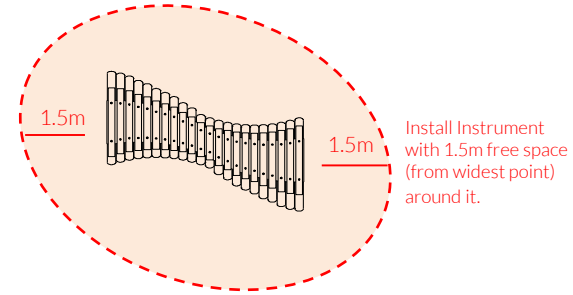

Instrument Components:

x8

M8 Nyloc Nut

x4

M6x20 Security Screw

x8

2 Part Cover

Cap

x2

M6 Saddle Strap

Metric

Conversion:

178mm/ 7"

232mm/ 9"

750mm/ 29 1/2"

850mm/ 33"

1.5m/ 59"



Pair Small Red Beaters X2

Surface Fix Components:

x2

M10x70 Security Screw

x2

M10 Barrel Nut

x8

2 Part Cover Cap



Ground Anchors not supplied

Spares available from www.musical-play.com or from your local distributor

28 Kg

Assembly Guide PDDUO

Tools:

 x1
 x2

TX 30 Driver Bit TX 45 Driver Bit



Surface Fixed
Duo
Page 2 of 3

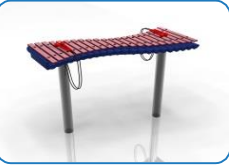

Instrument Components:

-  x8
M8 Nyloc Nut
-  x4
M6x20 Security Screw
-  x8
2 Part Cover Cap
-  x2
Cap
-  x2
M6 Saddle Strap

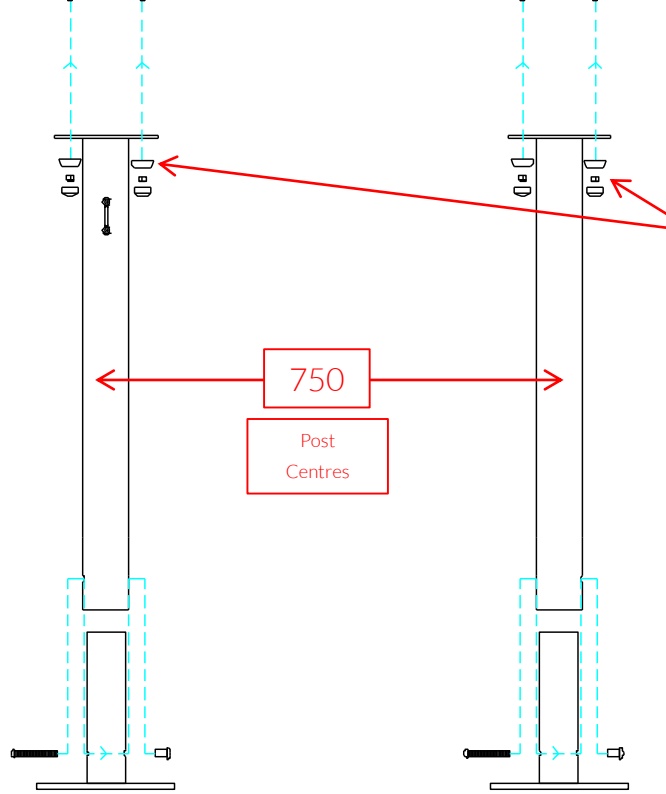
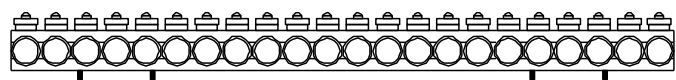



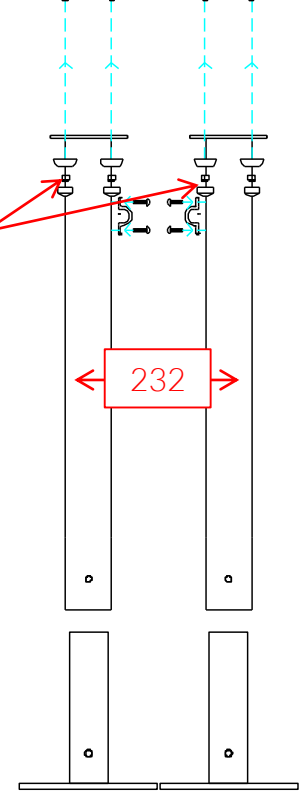
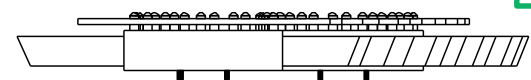





PPDUO FRONT



PPDUO SIDE

COMPONENTS LIST:

-  2 Part Cover Cap X8
-  M8 Nyloc nut X8
-  M10 Nut X8
-  M10x200 Threaded Bar X4
-  Saddle Strap X2
-  M6x20 Pin torx X4
-  M10x70 Pin torx X2
-  M10 Barrel Nut Pin torx X2

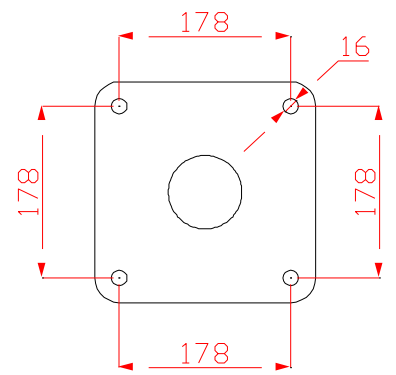



Thread Lock Solution Required (Not Supplied)



Pair Small Red Beaters X2

Surface Fix Components:

-  x2
-  x2
-  x8

Ground Anchors not supplied

Spares available from www.musical-play.com or from your local distributor

28 Kg

Surface Fix Post Installation



Tools:



Surface Fixed

Duo
Page 3 of 3

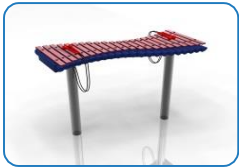

1

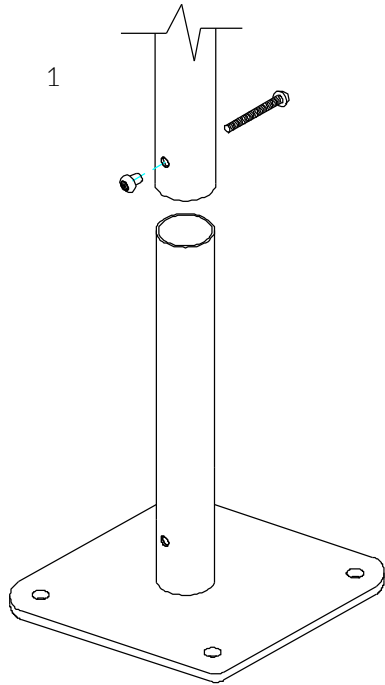

Locate the Surface fix Plate into the leg of the instrument.

2

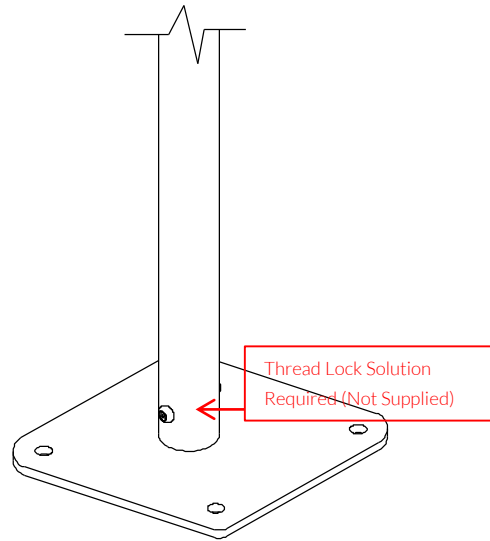

Fix instrument to Surface fix plate using M10 bolt and Barrel Nut and use **thread locking solution** to prevent fixings working loose.

3

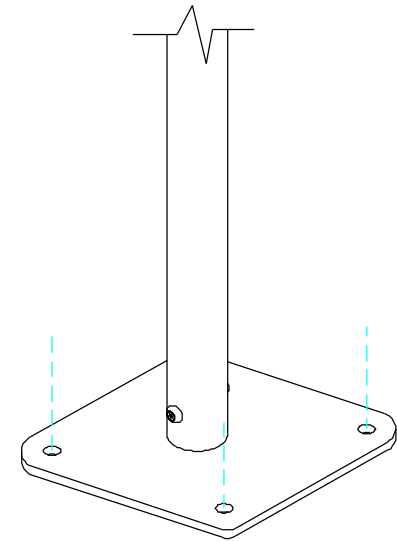

Fix Surface Plate to the ground surface **Ground Anchors Not provided** cover fixings with caps provided

Components:



x2

M10 Barrel Nut



x2

M10x70 Security Screw



x8

2 Part Cover Cap

Thread Lock Solution
Required (Not Supplied)

Installation Instructions

Surface Fixed

Emperor Chimes
Page 1 of 2



Instrument
Components:

Emperor
Chimes
are pre-
assembled

Metric Conversion:
100mm/ 4"
1.5m/ 59"
1785mm/ 70"
2490mm/ 98"

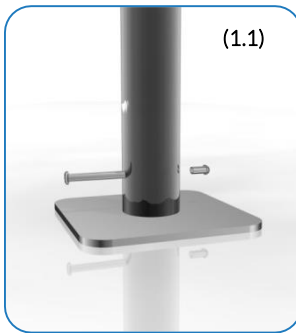

Weight of heaviest part 25kg (XL Chime)

1. Attach Surface Fixing plates to the base of each chime (1.1) (See Surface Fix Plate Installation Sheet)

2. Locate Chimes to desired location and mark holes to fix to desired surface.

4. Fix to Surface using recommended ground anchors not supplied

5. Make sure all fixings are covered and secure using cover caps provided

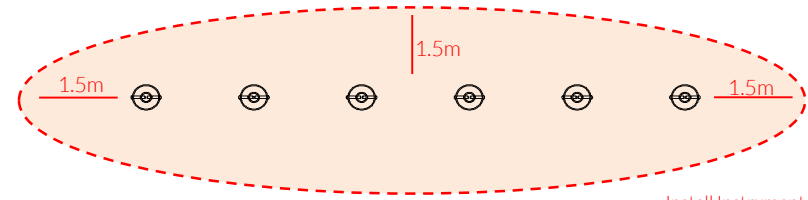

Install Instrument with 1.5m free space (from widest point) around it.

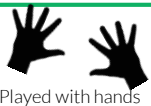
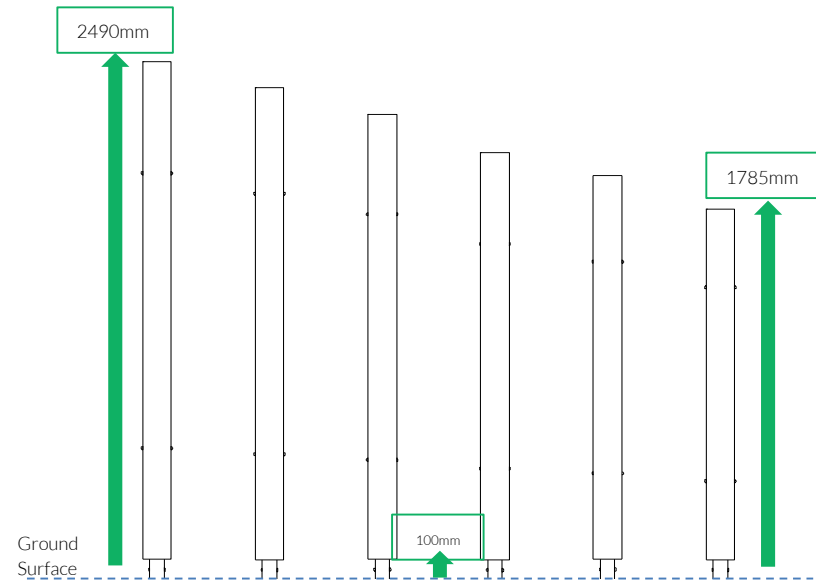

Played with hands

Surface Fix
Components:

 x6
M10x50 Security Screw

 x6
M10 Barrel Nut

 x24
2 Part Cover Cap

Spares available from
www.musical-play.com or
from your local distributor

117 Kg

Surface Fix Plate Installation

Tools:

 x2
TX 45 Driver Bit

Ground Fixed
Emperor Chimes
Page 2 of 2



Components:



x6

M10 Barrel Nut



x6

M10x50 Security Screw



x24

2 Part Cover Cap

Thread Lock Solution
Required (Not Supplied)

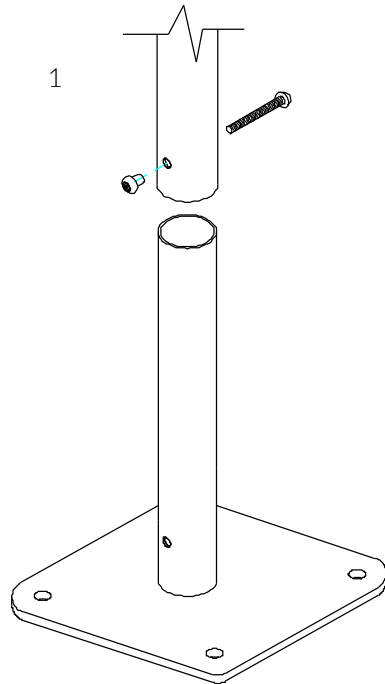

1
Locate the Surface fix Plate into the leg of the instrument.

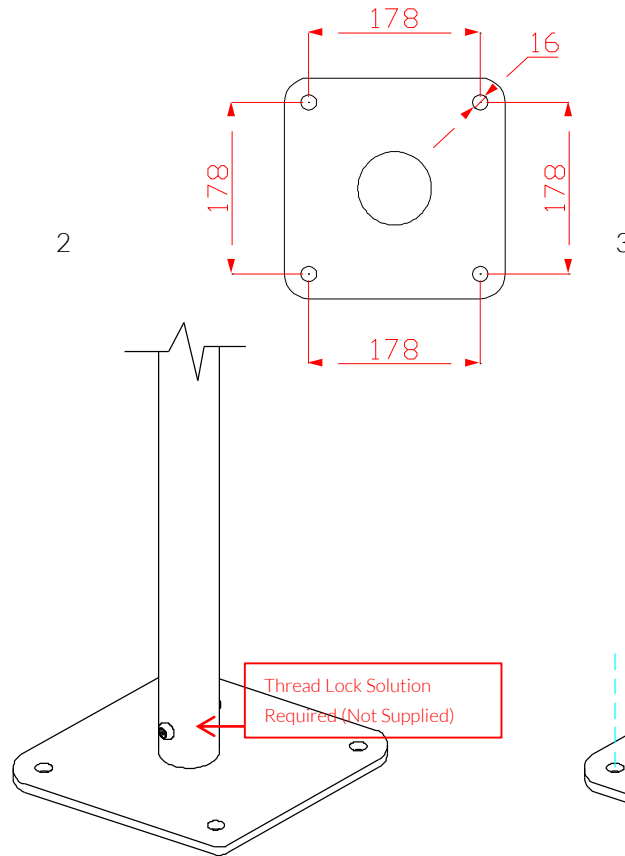

2
Fix instrument to Surface fix plate using M10 bolt and Barrel Nut and use **thread locking solution** to prevent fixings working loose.

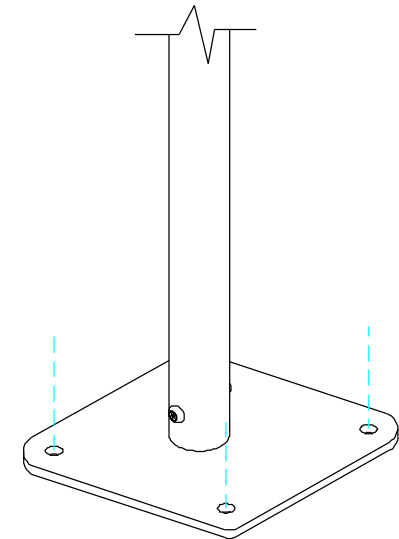

3
Fix Surface Plate to the ground surface **Ground Anchors Not provided** cover fixings with caps provided

Repeat Parts 1-3 for all 6 chimes

Installation Instructions

Surface Fixed

Freechimes
Alto/ Soprano
Page 1 of 3



Metric Conversion:
600mm/ 24"
800mm/ 31"
950mm/ 37"
1200mm/ 47"
1.5m/ 59"

Weight of heaviest part **8.35kg** (Freechimes)

1. Carefully lay 2 x legs on a **level surface** and check distance between **legs is equal**. Line up pre drilled holes in the backboards with the holes in legs and ensure the instrument is aligned square with the legs. **Fix** in place using **M8x40mm screws** supplied (see installation guide)

2. Attach Surface Fixing posts to legs (See **Surface Fix Post Installation Sheet**)

3. **Locate Instrument** in desired location and mark holes to fix to desired surface.

4. **Fix Surface Plate** to level surface using Coachscrews, Rawlbolts, chemical anchors or similar as deemed appropriate by Installer.

(It is your responsibility to ensure that the existing surface is suitable to receive the appropriate fixing)

5. Make sure all fixings are covered and secure using cover caps provided

6. Beaters can be fixed to Steel posts with fixings provided

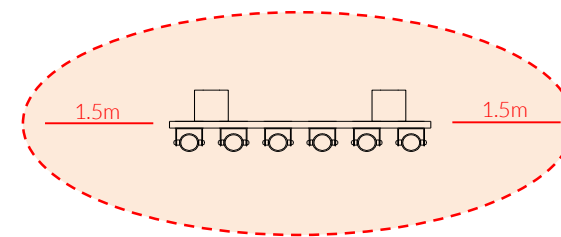

Install Instrument with 1.5m free space (from widest point) around it.

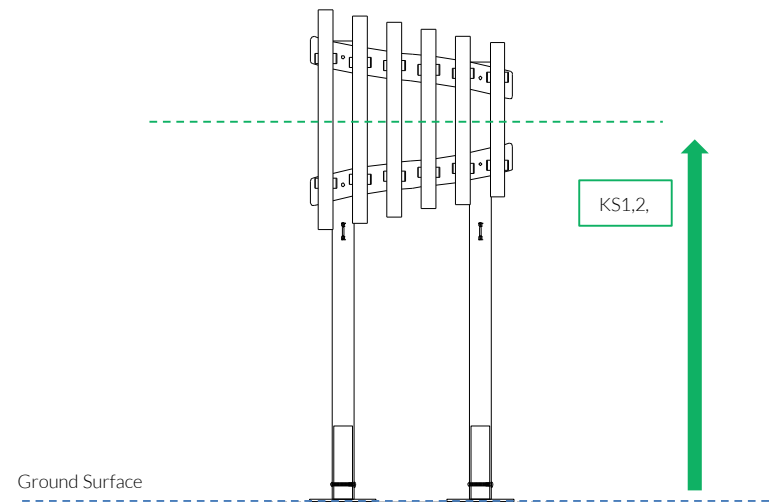

KS1 - 800mm
KS2 - 950mm
Adult - 1200mm



Pair Small Beaters X1

Ground Fix Components:

x8
2 Part Cover Cap

x2
M10 Barrel Nut

x2
M10x70 Security Screw

Spares available from www.musical-play.com or from your local distributor

16 Kg

Assembly Guide PPFREC



Surface Fixed

Freechimes
Alto/ Soprano
Page 2 of 3



Components:



Eye Straps
X2



M6x20mm
Secure Screw
X4



M8x40mm
Secure Screw
X4

Thread Lock Solution
Required (Not Supplied)

709mm Diatonic Post Centres

472mm Pentatonic Post Centres

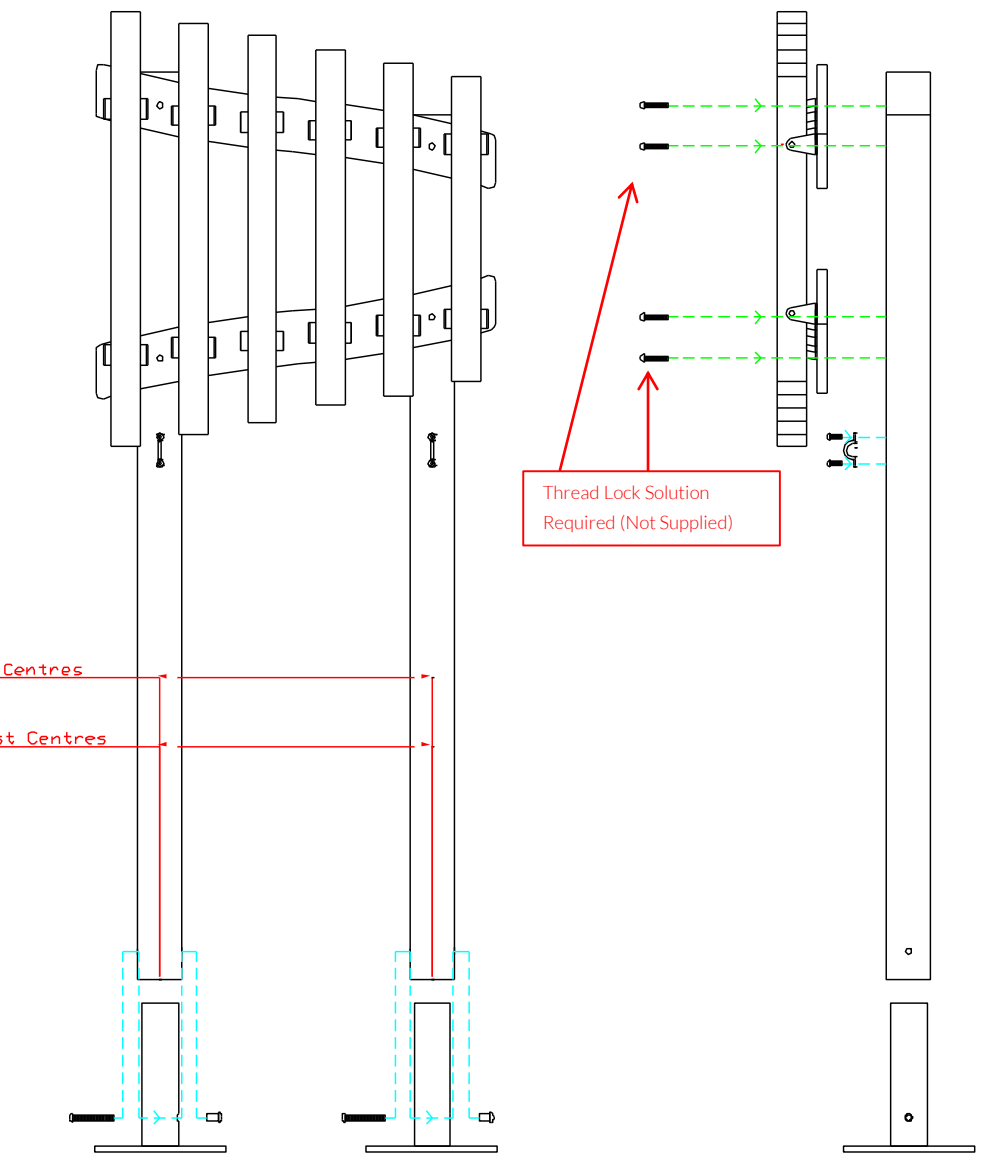

Tools:

- x1
- x2

TX 30 Driver Bit TX 45 Driver Bit

COMPONENTS LIST:

- Saddle Strap X2
- M6x20 Pin torx X4
- M8 X 40 Pin Torx X4
- M10x70 Pin torx X2
- M10 Barrel Nut Pin torx X2

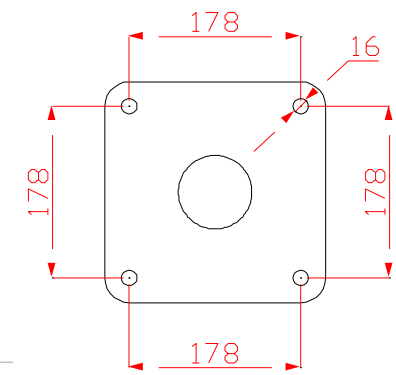

Pair Small Beaters X1

Ground Fix
Components:

- x8
- x2
- x2

Spares available from
www.musical-play.com or
from your local distributor

16 Kg

Surface Fix Post Installation



Tools:

x2
TX 45 Driver Bit

Surface Fixed

Freechimes
Alto/ Soprano
Page 3 of 3



Components:



x2

M10 Barrel Nut



x2

M10x70 Security Screw



x8

2 Part Cover Cap

Thread Lock Solution
Required (Not Supplied)

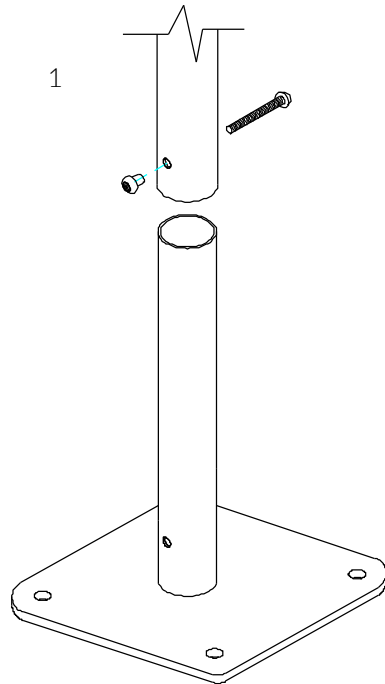

1
Locate the Surface fix Plate into the leg of the instrument.

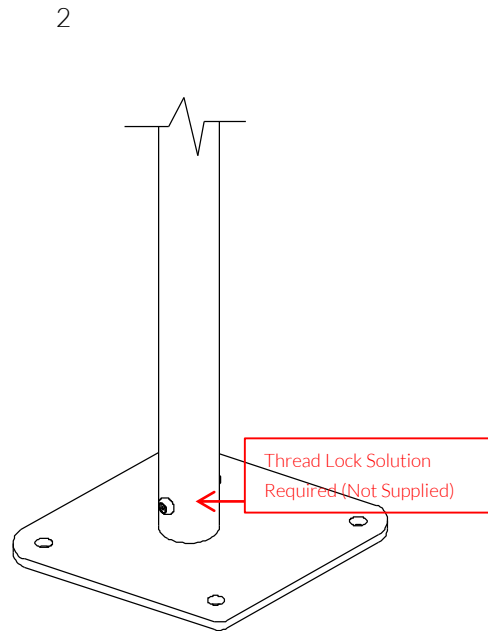

2
Fix instrument to Surface fix plate using M10 bolt and Barrel Nut and use **thread locking solution** to prevent fixings working loose.

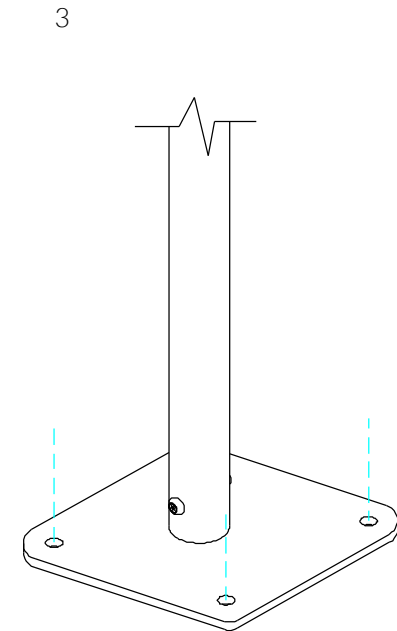

3
Fix Surface Plate to the ground surface **Ground Anchors Not provided** cover fixings with caps provided