

Installation Instructions

Surface Fixed

Bell Lyre
Page 1 of 2



Weight of heaviest part 14.4kg (Bell Lyre)

1. Attach Surface Fixing posts to legs (See Surface Fix Post Installation Sheet)

2. Locate Plate in desired location and mark holes to fix to desired surface.

3. Fix Surface Plate to level surface using Coachscrews, Rawlbolts, chemical anchors or similar as deemed appropriate by Installer.

(It is your responsibility to ensure that the existing surface is suitable to receive the appropriate fixing)

4. Make sure all fixings are covered and secure using cover caps provided

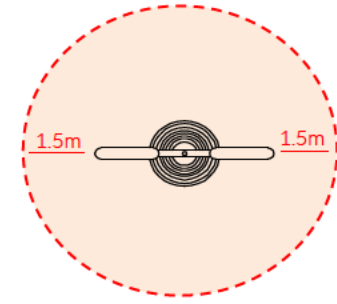

Install Instrument with 1m free space (from widest point) around it.

1525mm

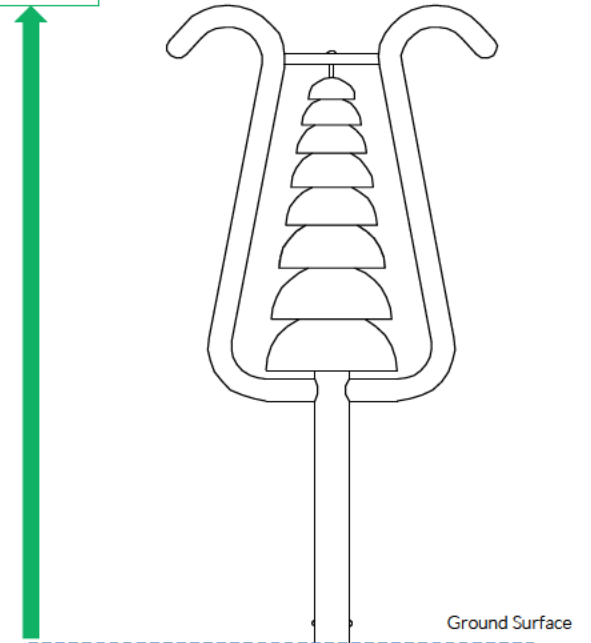

Ground Surface

CAUTION: Bell Lyre surface can get hot in direct sunlight, if possible install in shaded areas.



Pair Small Red Beaters X1

Ground Fix Components:



2 Part Cover Cap x4



x1



x1

M10x70 Security Screw M10 Barrel Nut

Ground Anchors not supplied

Spares available from www.musical-play.com or from your local distributor

23.5 Kg

Surface Fix Post Installation

Tools:

 x2
TX 45 Driver Bit

Surface Fixed

Bell Lyre
Page 2 of 2

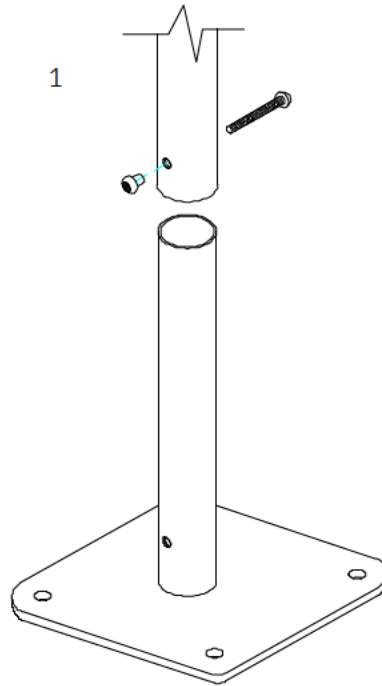

1
Locate the Surface fix Plate into the leg of the instrument.

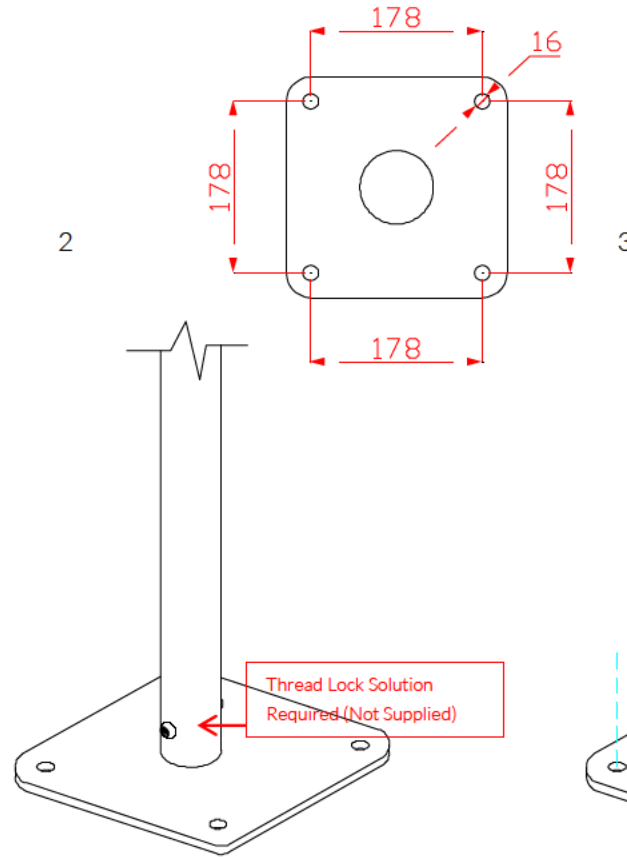

2
Fix instrument to Surface fix plate using M10 bolt and Barrel Nut and use **thread locking solution** to prevent fixings working loose.

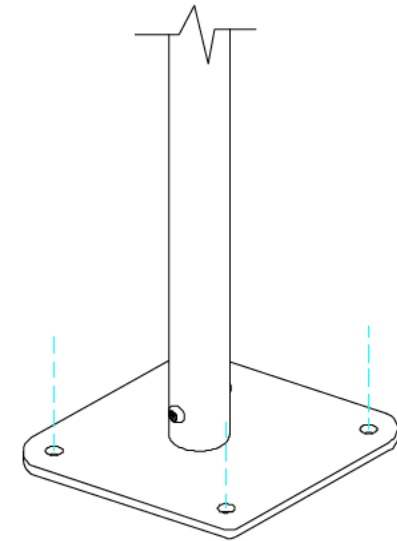

3
Fix Surface Plate to the ground surface **Ground Anchors Not provided** cover fixings with caps provided

Components:



x1

M10 Barrel Nut



x1

M10x70 Secur ty Screw



x4

2 Part Cover Cap

Thread Lock Solution
Required (Not Supplied)