

# Installation Instructions

## Surface Fixed

Djembes  
Page 1 of 2

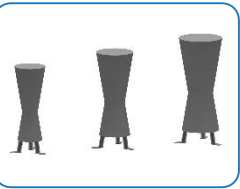

Instrument  
Components:

Djembes  
are pre-  
assembled

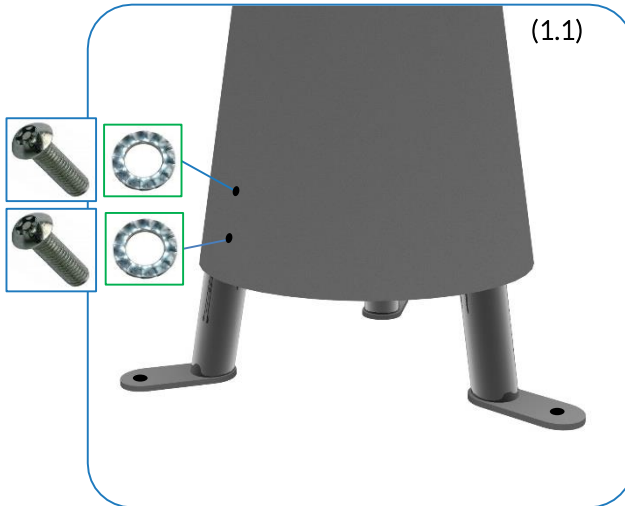
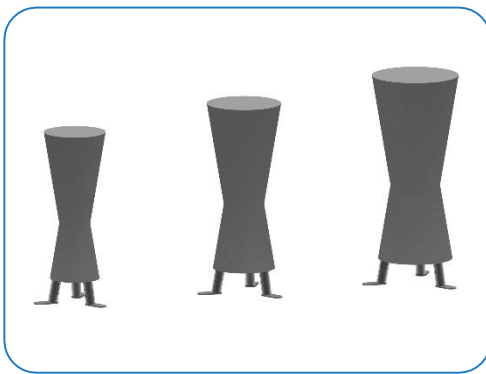

Weight of heaviest part 23kg (Large Djembe)

1. Assemble Ground Fixing Posts to base of sambas using M8x25mm security screws and lock washers. (1.1)( See Assembly Guide)

2. Arrange Djembes in desired location and mark holes to fix to desired surface.

3. Fix to Surface using recommended ground anchors (Ground Anchors are not supplied)

4. Make sure all fixings are covered and secure using cover caps provided

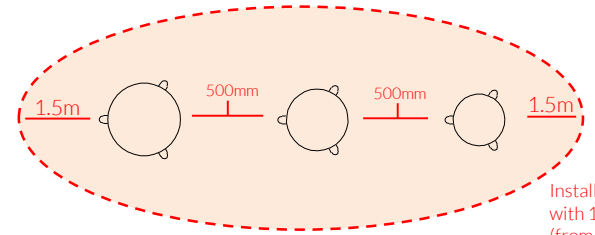

Install Instrument with 1.5m free space (from widest point) around it.

**CAUTION:** Drum surface can get hot in direct sunlight, if possible install in shaded areas.

Djembes will arrive on site in pre set heights.

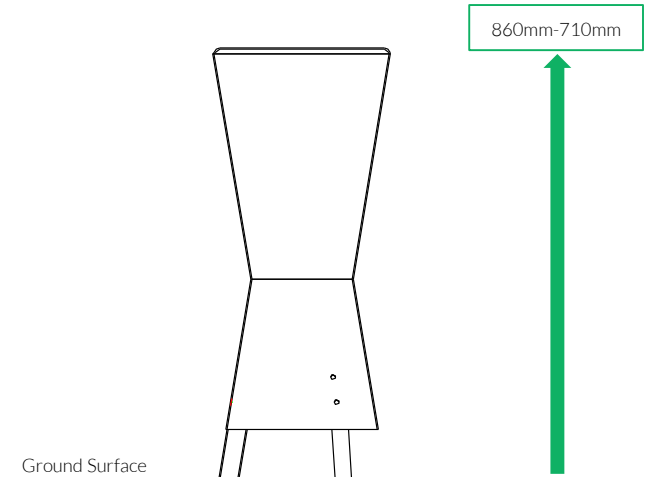

Surface Fix  
Components:

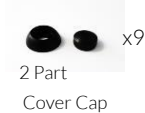

Spares available from  
[www.musical-play.com](http://www.musical-play.com) or  
from your local distributor

48 Kg

# Assembly Guide PPDJEM



Tools:



x1  
TX 40 Driver Bit

## Surface Fixed

Djembes  
Page 2 of 2

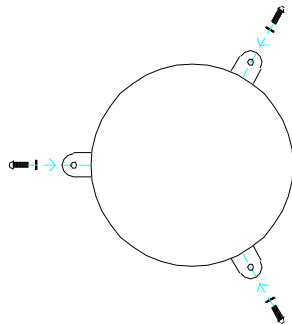
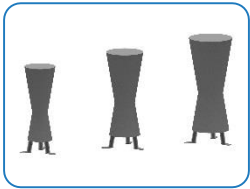

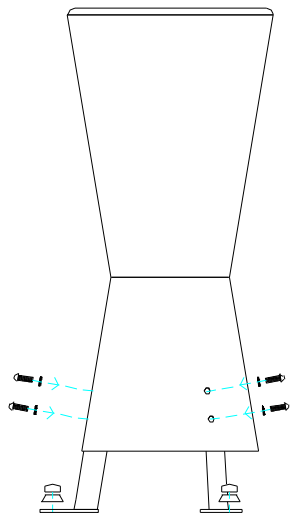

## Instrument Components:

Djembes are pre-assembled



### COMPONENTS LIST:

-  M8x25 Pin torx X18
-  M8 Lock washer X18
-  2 Part Cover Cap X9

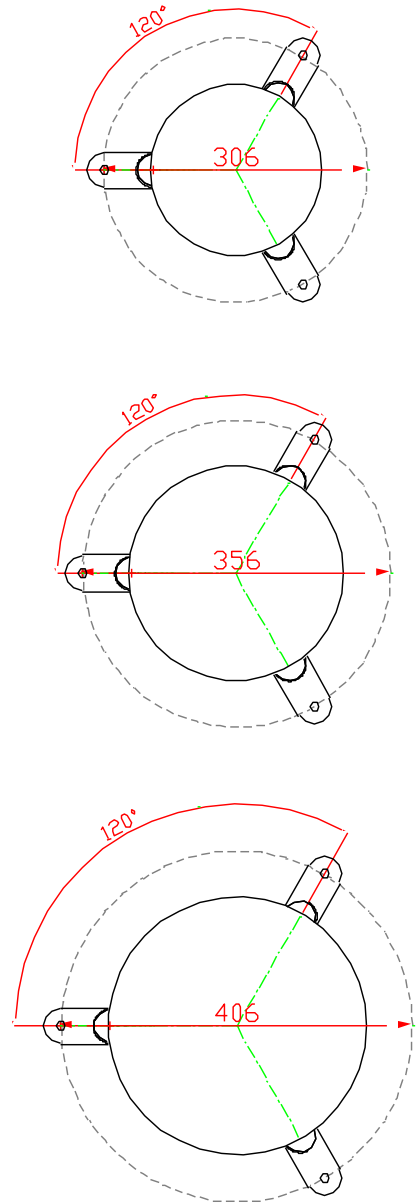

Played with hands

Surface Fix Components:



x18  
M8x25 Security Screw



x18  
M8 Lock Washer



x9  
2 Part Cover Cap

Spares available from  
[www.musical-play.com](http://www.musical-play.com) or  
from your local distributor

44 Kg

# Ground Fix Installation

Tools:



x1  
TX 40 Driver Bit

## Surface Fixed

Djembes  
Page 3 of 4



1

Attach Ground Fix Legs to base of each drum using M8x25 Bolts and lock washers provided.

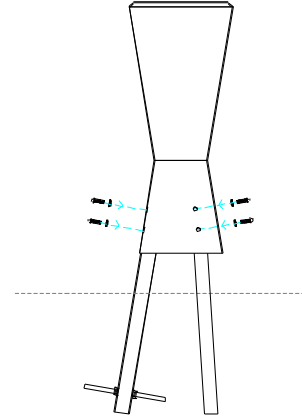
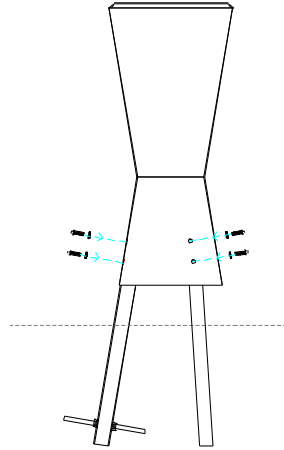
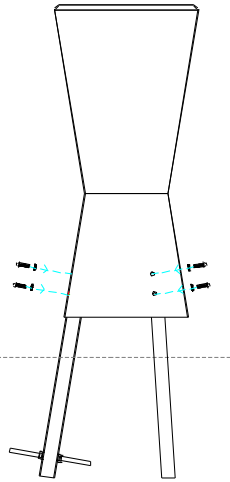

2

Excavate 3 holes 350mm deep. Each hole should taper down making the base diameter at least 100mm larger than the surface hole

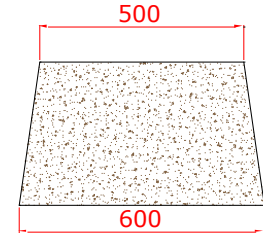
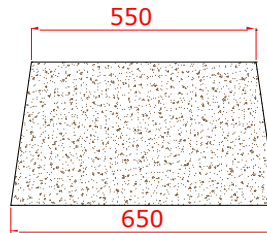
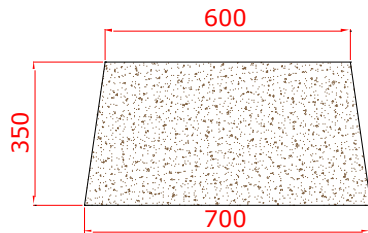
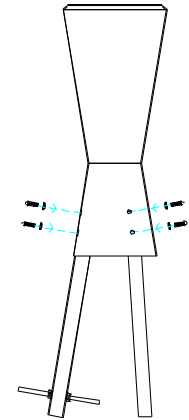
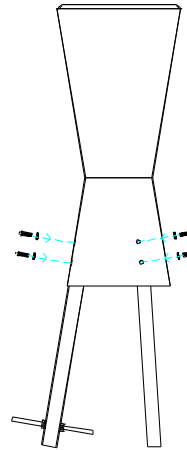
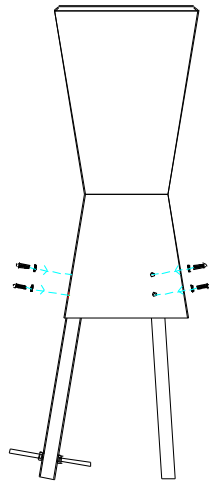

## Components:



# Ground Fix Installation

Foundations should not present a hazard. These foundations are recommended as a guide, for more information on foundation details for various surface see Part 1 of BS EN 1176.

## Surface Fixed

Djembes  
Page 4 of 4



Components:



x18

M8x25mm Pin Torx



x18

M8 Lock Washer

Metric Conversion:

- 50mm/ 2"
- 350mm/ 14"
- 500mm/ 19.5"
- 550mm/ 21.5"
- 600mm/ 24"
- 650mm/ 25.5"
- 700mm/ 27.5"

3

Compact each hole with a maximum of 50mm of aggregate and lower each samba into its hole

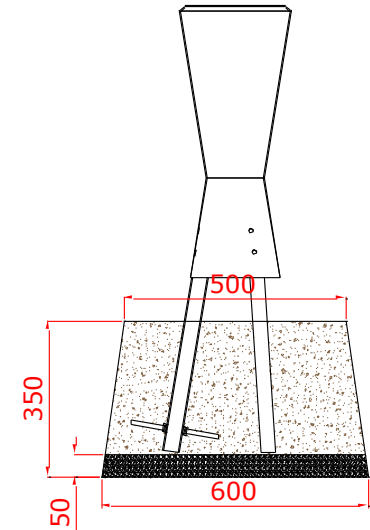
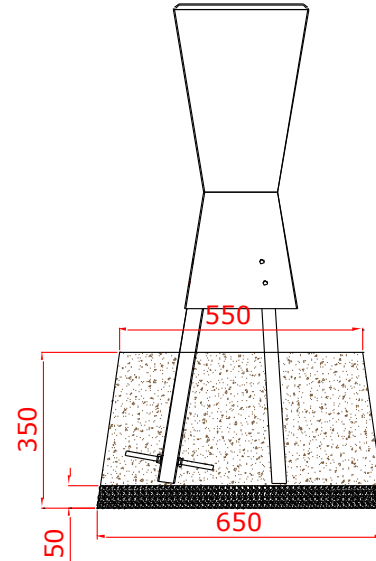
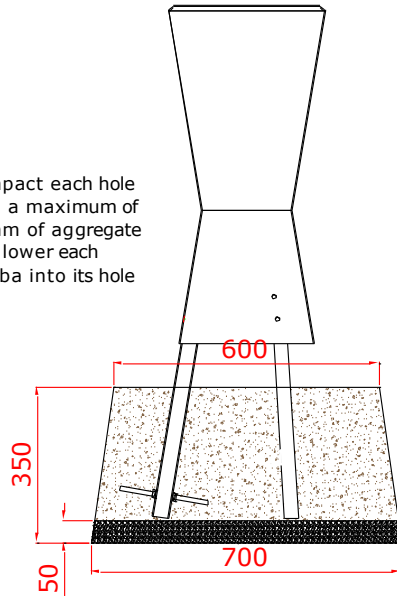

4

Fill each hole with fast drying concrete to manufacturers specifications.

