

Installation Instructions

Ground Fixed

Harmony Bells
Page 1 of 3



Instrument
Components:

Metric Conversion:
400mm/ 16"
1650mm/ 64 61/64"
1.5m/ 59"

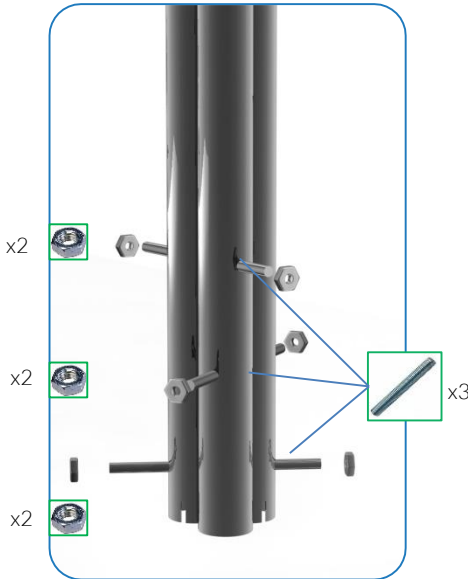

Weight of heaviest part **8Kg** (Large Bell)

1. Unpack ground fixing legs 3no.

2. Lay packaging out on floor or assemble on non-abrasive surface to prevent marking of polished stainless steel.

3. Align holes on legs (opposite end to polished domes) and secure in place using 3no. M10 x 200mm threaded bar and 6no. M10 nuts provided
Tools required 2no. 17mm metric spanner/wrench (¹¹/₁₆ inch or alternatively using adjustable wrench)

4. Invert assembled frame so Bells are at the top.

5. Excavate a hole for the frame **250mm diameter by 450 deep** in desired location upon decision from customer. (See Ground Fix Post Installation)

6. Locate (lower) frame into hole making sure that the flowers are level and upright.

5. Once happy with location of the Flowers, **fill hole using rapid hardening concrete**. Be sure to compact concrete around legs and leave to dry according to manufactures guidelines.

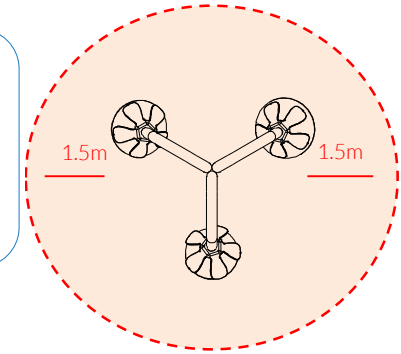

Install Instrument with 1.5m free space (from widest point) around it.

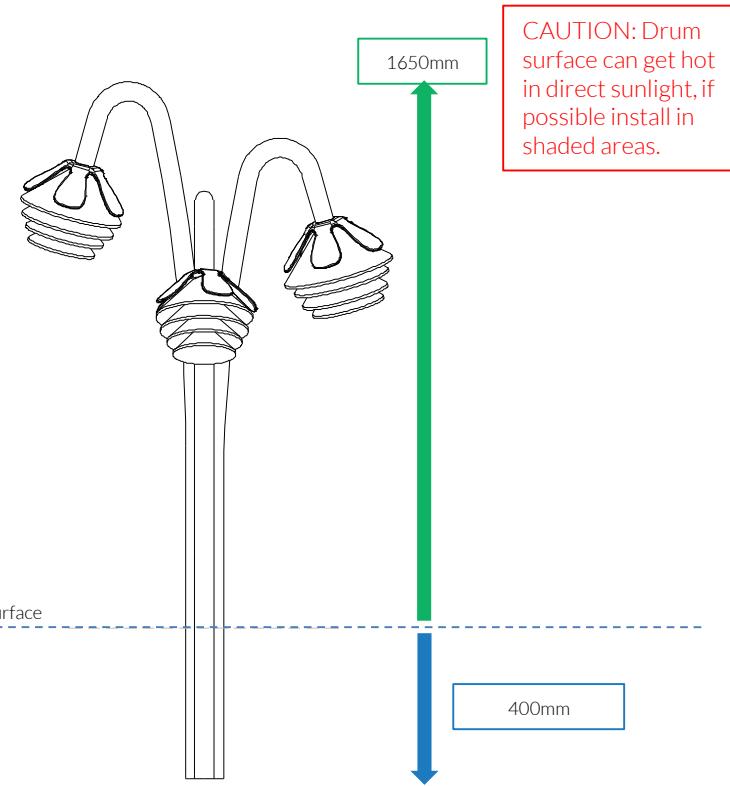

CAUTION: Drum surface can get hot in direct sunlight, if possible install in shaded areas.



Small Beaters X3

Ground Fix Components:



x3
M10x200 Threaded bar



x6
M10BZP Nut

Spares available from www.musical-play.com or from your local distributor

24 Kg

Ground Fixed

Harmony Bells
Page 2 of 3



Instrument
Components:

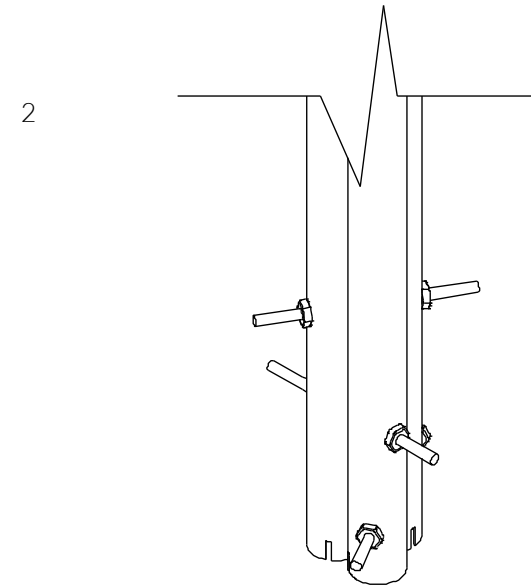
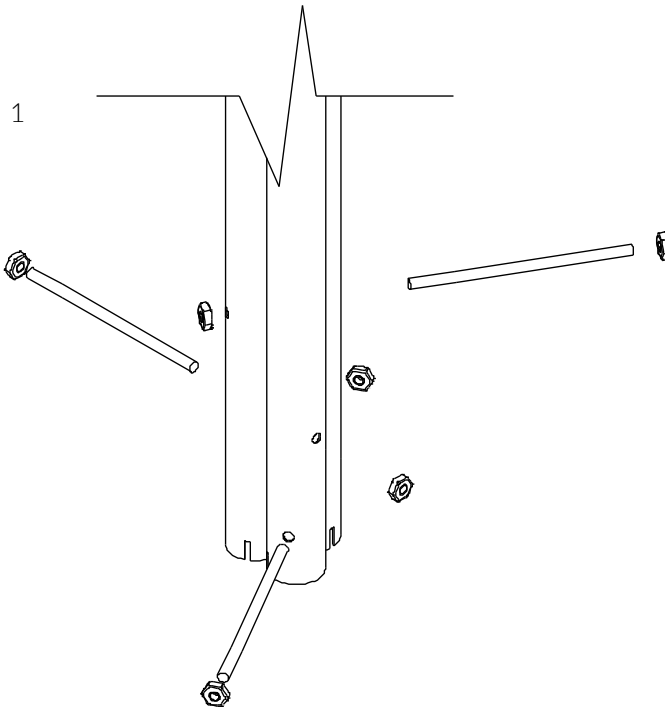

Small
Beaters X3

Ground Fix
Components:

 x3
M10x200 Threaded bar

 x6
M10BZP Nut

Spares available from
www.musical-play.com or
from your local distributor

24 Kg

Ground Fix Installation

Ground Fixed

Harmony Bells
Page 3 of 3



Components:



x3

M10x200 Threaded Bar



x6

M10 BZP Nut

Metric Conversion:

50mm/ 2"
250mm/ 10"
350mm/ 14"
400mm/ 16"
450mm/ 18"

1 Insert M10x 200 Threaded bar into pre drilled holes in Frame of Flowers using M10 BZP Nuts

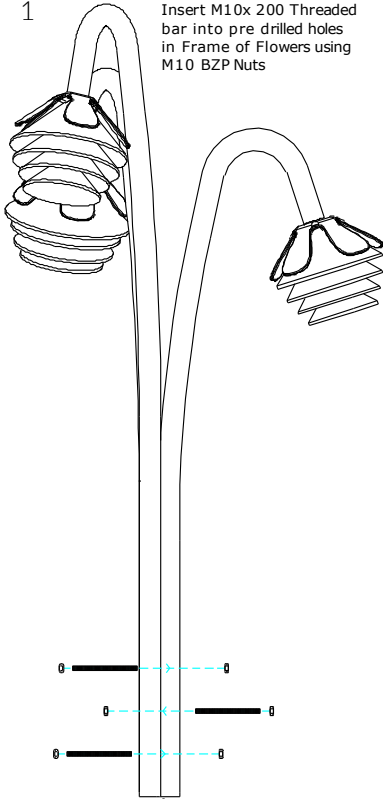

2 Excavate a holes with a 250mm diameter tapering down to 350mm diameter and 450mm depth

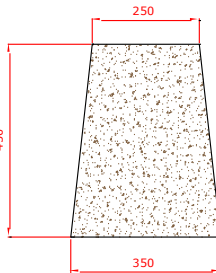
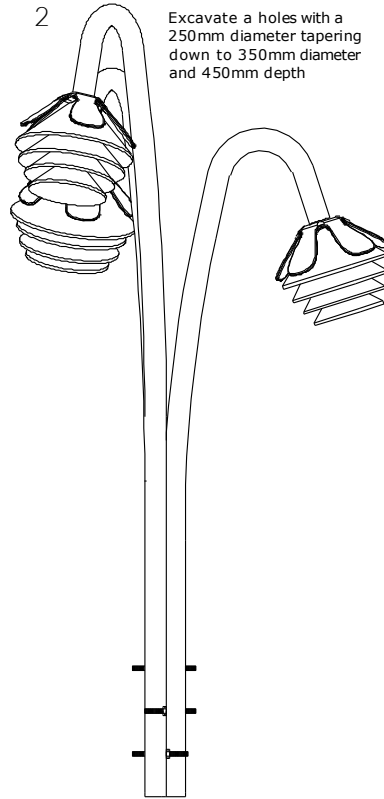

If Flower needs to be positioned lower a deeper hole can be excavated.

3 Compact base of hole with 50mm of aggregate. Lower ground Fix post attached to instrument straight and level before filling with concrete

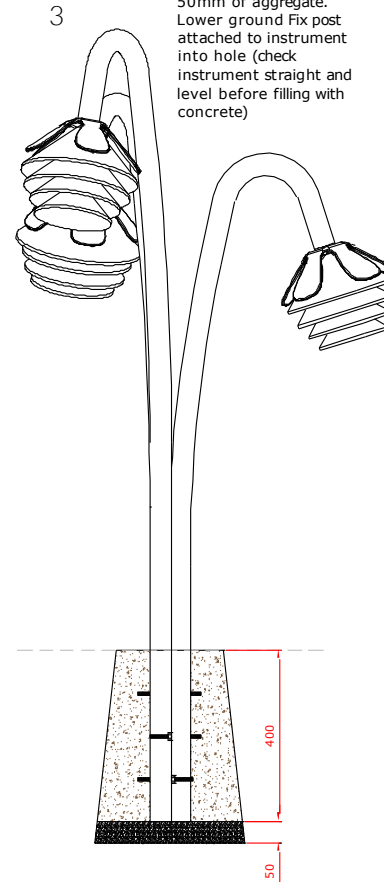

4 Fill hole with fast drying concrete to manufacturers specifications.

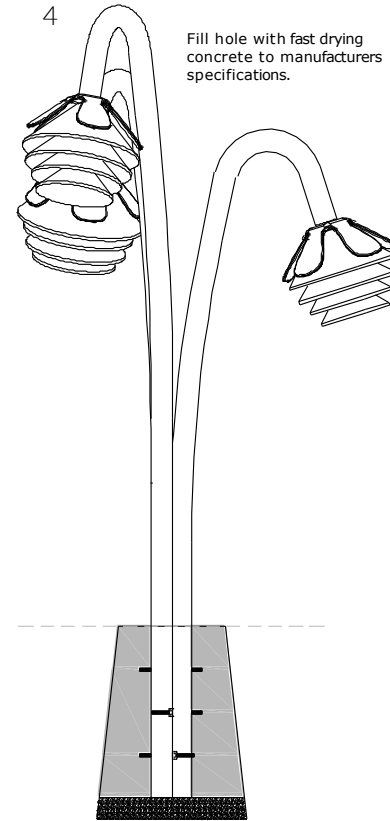

Foundations should not present a hazard. These foundations are recommended as a guide, for more information on foundation details for various surface see Part 1 of BS EN 1176.