

Installation Instructions

Surface Fixed

Harmony Bells
Page 1 of 2



Instrument
Components:

Metric Conversion:
1650mm/ 64 61/64"
1.5m/ 59"

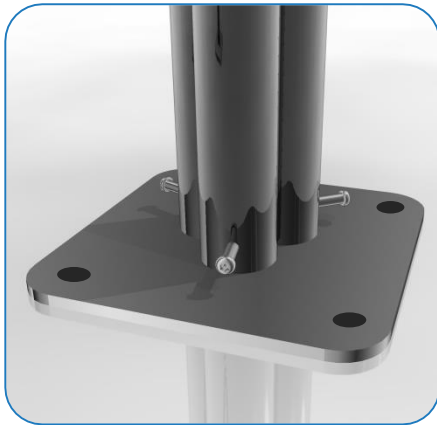

Weight of heaviest part **8kg** (Large Bell)

1. Unpack ground fixing legs
3no.

2. Lay packaging out on floor
or assemble on non-abrasive
surface to prevent marking of
polished stainless steel.

3. Align holes on legs to holes
on surface fixing (opposite
end to polished domes) and
secure in place using 3no.
M10 x 30mm Screws
provided. Tools required TX
45 Driver Bit)

4. Invert assembled frame so
Bells are at the top.

5. **Locate Bells** in desired
location and mark holes to fix
to desired surface.

6. Fix to Surface using
recommended ground
anchors (**Ground Anchors
are not supplied**)

7. Make sure all fixings are
covered and secure using
cover caps provided

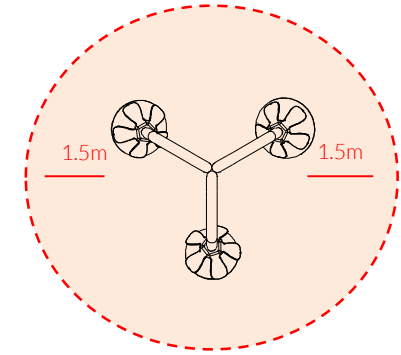

Install
Instrument
with 1.5m free
space (from
widest point)
around it.

1650mm from Plate

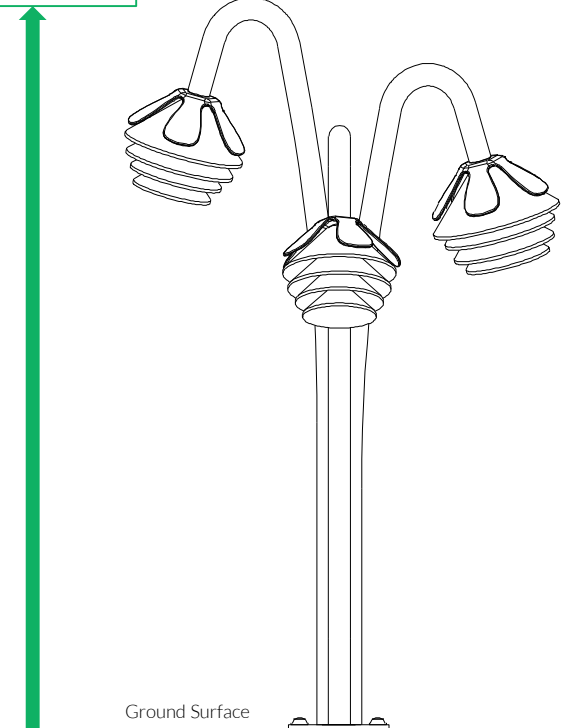

Small
Beaters X3

Surface Fix
Components:



x3

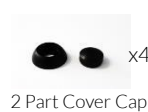

x4

2 Part Cover Cap

**Ground Anchors
not supplied**

Spares available from
www.musical-play.com or
from your local distributor

30 Kg

Tools:

 x1
TX 45 Driver Bit

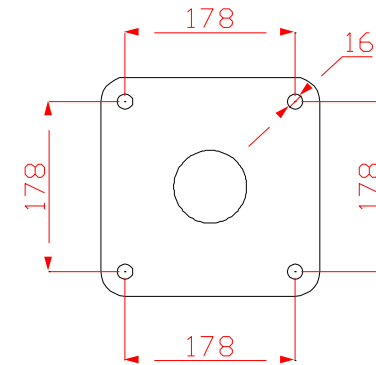

Surface Fixed

Harmony Bells
Page 2 of 2



Instrument
Components:

Thread Lock Solution
Required

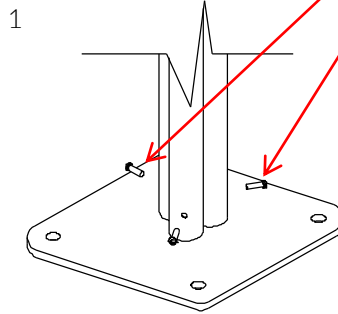

1
Locate the Surface fix Plate into the leg of the instrument.

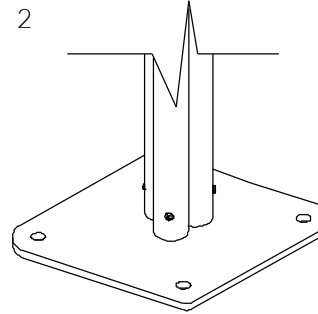

2
Fix instrument to Surface fix plate using M10 Screws and use **thread locking solution** to prevent fixings working loose.

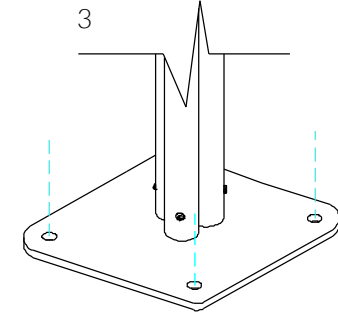

3
Fix Surface Plate to the ground surface **Ground Anchors Not provided** cover fixings with caps provided

Thread Lock Solution
Required



Small
Beaters X3

Surface Fix
Components:



x3



x4

Ground Anchors
not supplied

Spares available from
www.musical-play.com or
from your local distributor

30 Kg