

# Installation Instructions

## Surface Fixed

Harmony Bell  
Page 1 of 2



Instrument  
Components:

Metric Conversion:  
1650mm/ 64 61/64"  
1500mm/ 59 1/16"  
1350mm/ 53 5/32"  
1.5m/ 59"

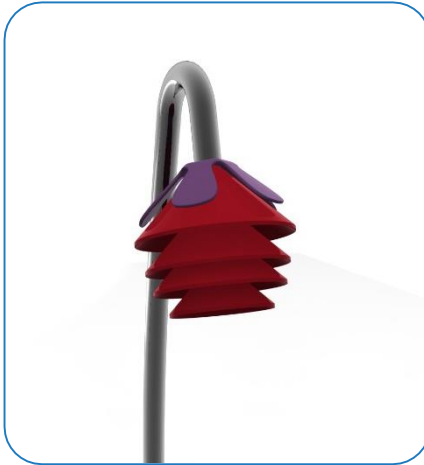

Weight of heaviest part **8kg** (Large Bell)

1. Unpack ground fixing leg  
1no.

2. Lay packaging out on floor  
or assemble on non-abrasive  
surface to prevent marking of  
polished stainless steel.

3. Align holes on leg to holes  
on surface fixing plate  
(opposite end to polished  
domes) and secure in place  
using 1no. M10 x 40mm  
Screw and Barrel Nut  
provided. Tools required TX  
45 Driver Bits)

4. Invert assembled frame so  
Bells are at the top.

5. **Locate Bells** in desired  
location and mark holes to fix  
to surface.

6. Fix to Surface using  
recommended ground  
anchors (**Ground Anchors  
are not supplied**)

7. Make sure all fixings are  
covered and secure using  
cover caps provided

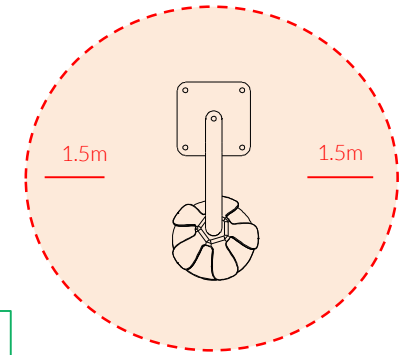

Install  
Instrument  
with 1.5m free  
space (from  
widest point)  
around it.

Large 1650mm  
Medium 1500mm  
Small 1350mm  
from plate

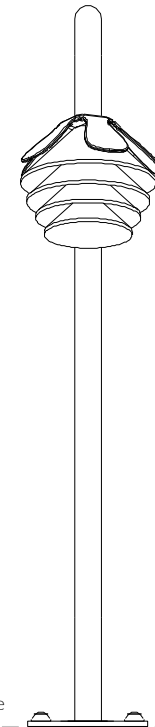

Ground Surface



Small  
Beaters X1

Surface Fix  
Components:

M10x40 Security Screw x1

M10 Barrel Nut x1

2 Part Cover Cap x4

**Ground Anchors  
not supplied**

Spares available from  
[www.musical-play.com](http://www.musical-play.com) or  
from your local distributor

14 Kg

# Assembly Guide PPHARMB

Tools:



x1  
TX 45 Driver Bit

## Surface Fixed

Harmony Bell  
Page 2 of 2



Instrument  
Components:

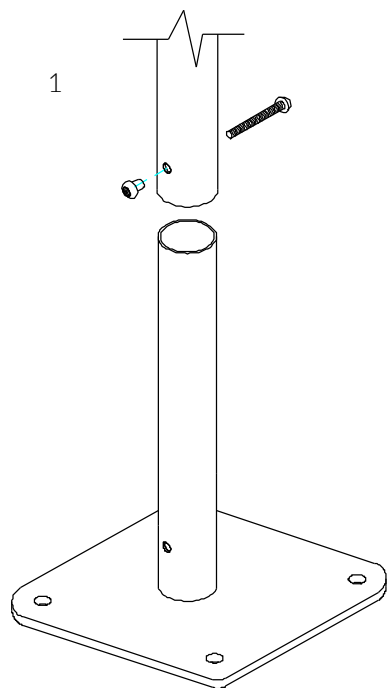

1  
Locate the Surface fix Plate into the leg of the instrument.

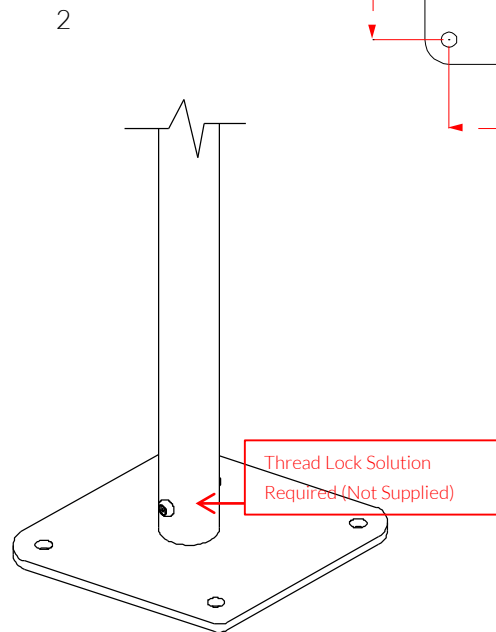

2  
Fix instrument to Surface fix plate using M10 bolt and Barrel Nut and use **thread locking solution** to prevent fixings working loose.

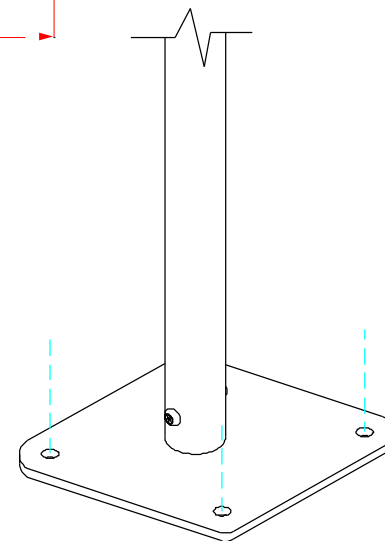
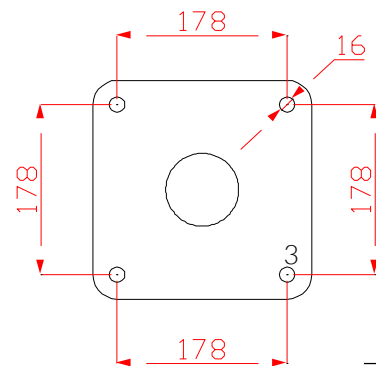

3  
Fix Surface Plate to the ground surface **Ground Anchors Not provided** cover fixings with caps provided

Thread Lock Solution  
Required



Small Beaters X1

Surface Fix Components:



x1



x1



x4

Ground Anchors  
not supplied

Spares available from  
[www.musical-play.com](http://www.musical-play.com) or  
from your local distributor

30 Kg