

# Installation Instructions

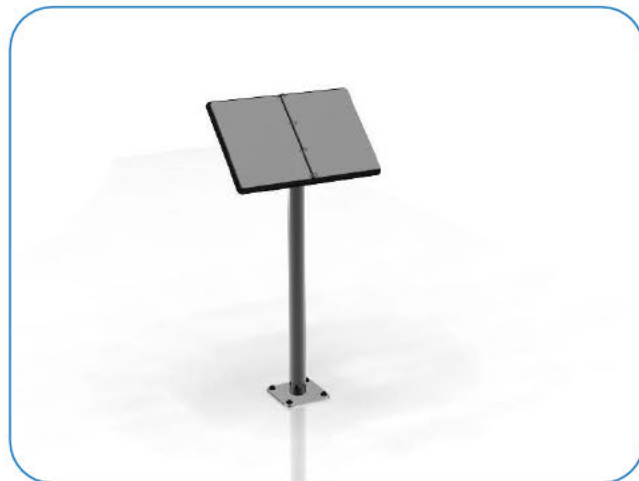

1. Attach the steel legs to the base of the instrument with the M8 Nyloc Nuts and 2 part security caps. (1.1) (See Assembly Guide)

2. Attach Surface Fixing posts to legs (1.2) (See Ground Fix Post Installation Sheet)

3. Locate Plate in desired location and mark holes to fix to desired surface.

4. Fix to Surface using recommended ground anchors not supplied

5. Make sure all fixings are covered and secure using cover caps provided

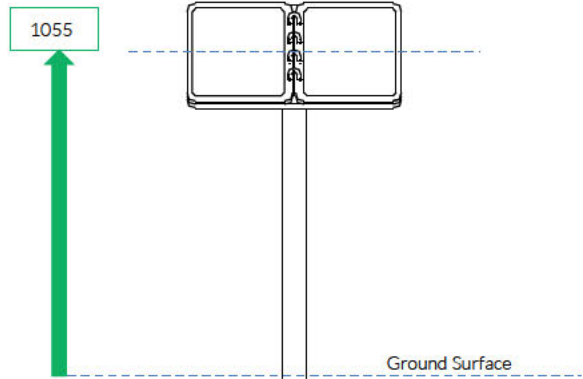
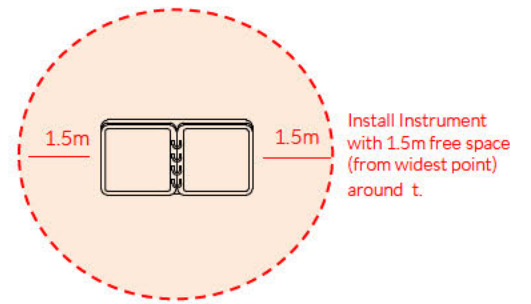

## Surface Fixed

Music Book  
Page 1 of 3



## Instrument Components:

-  x4  
M8 Nyloc Nut
-  x4  
2 Part Cover Cap M8

Metric  
Conversion:  
250mm/ 10"  
300mm/ 12"  
450mm/ 18"  
700mm/ 28"  
850mm/ 33"  
1.5m/ 59"

Weight of heaviest part 10kg (Music Book)



## Ground Fix Components:

-  x2  
M10x200 Bolt
-  x4  
M10 Nut
-  x1  
M10 Barrel Nut
-  x1  
M10x70 Security Screw

Spares available from  
[www.musical-play.com](http://www.musical-play.com) or  
from your local distributor

19.5 Kg

# Assembly Guide PPMUSIC



## Surface Fixed

Music Book  
Page 2 of 3



### Instrument Components:

 x4  
M8 Nyloc Nut

 x4  
2 Part Cover Cap M8

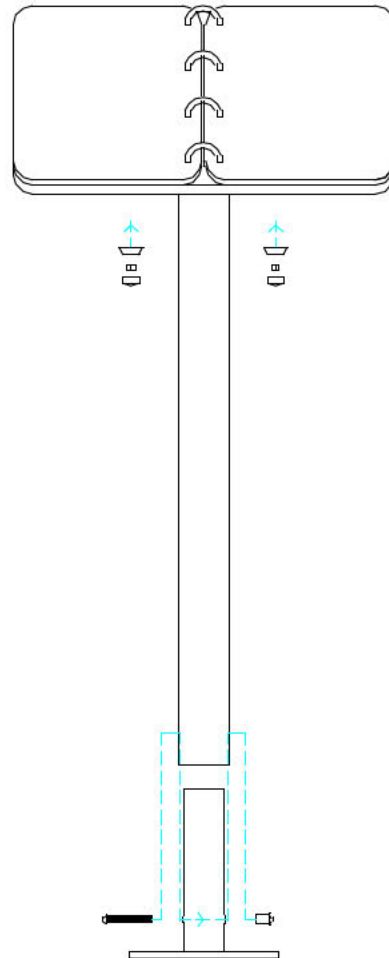

PPCONG FRONT

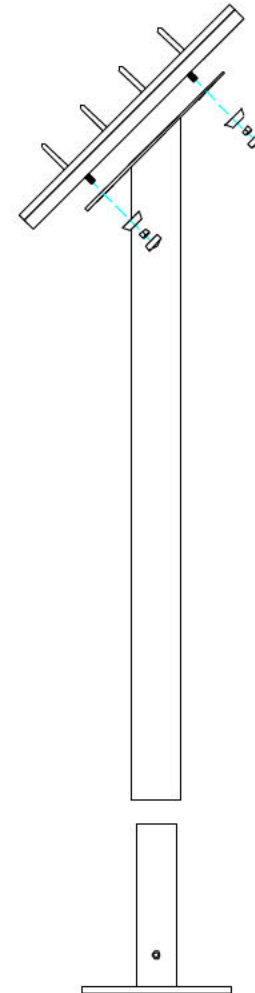

PPCONG SIDE

### COMPONENTS LIST:



2 Part Cover Cap M8 X4



M8 Nyloc nut X4



M10x70 Pin torx X1





M10 Barrel Nut Pin torx X1



Used with hands

### Surface Fix Components:

 x1  
M10 Barrel Nut

 x1  
M10x70 Security Screw

Spares available from  
[www.musical-play.com](http://www.musical-play.com) or  
from your local distributor

19.5 Kg

# Surface Fix Post Installation

## Surface Fixed

Music Book  
Page 3 of 3



### Components:



x1



x1

M10x70 Security Screw



x4

2 Part Cover Cap

Thread Lock Solution  
Required (Not Supplied)

#### Metric Conversion:

50mm/ 2"  
250mm/ 10"  
300mm/ 12"  
350mm/ 14"  
400mm/ 16"  
450mm/ 18"

1

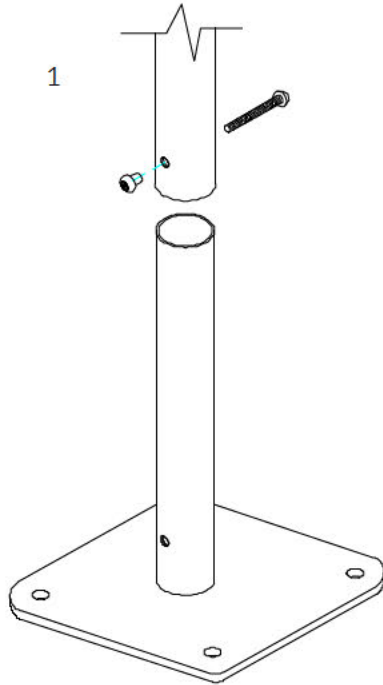

Locate the Surface fix Plate into the leg of the instrument.

2

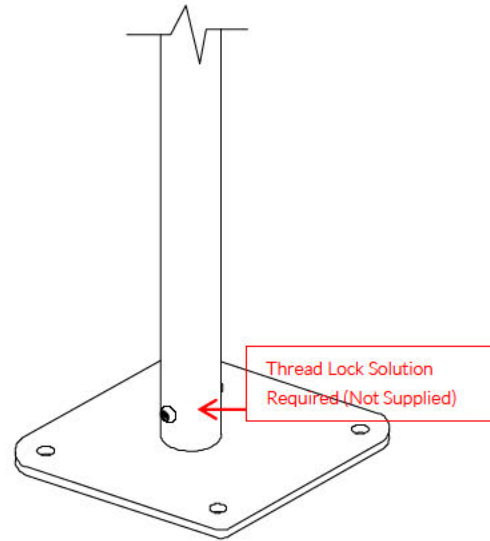

Fix instrument to Surface fix plate using M10 bolt and Barrel Nut and use **thread locking solution** to prevent fixings working loose.

3

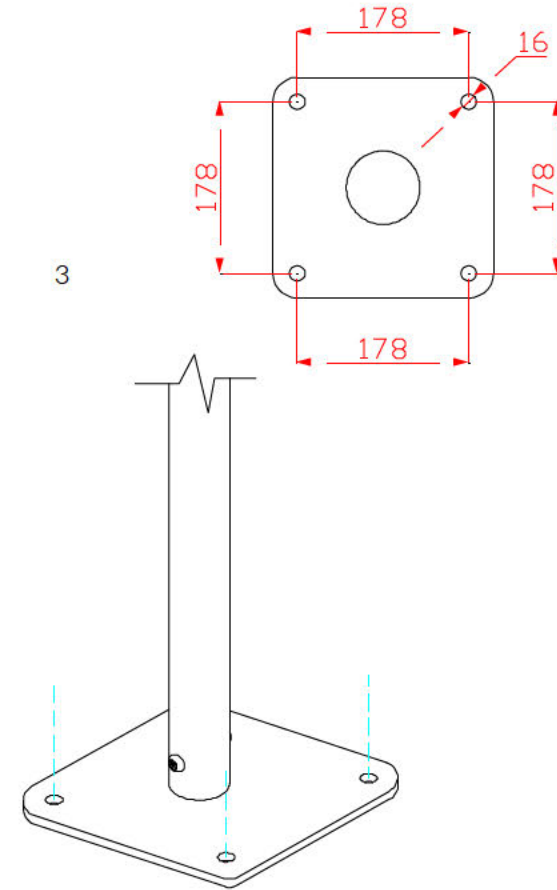

Fix Surface Plate to the ground surface **Ground Anchors Not provided** cover fixings with caps provided