

Installation Instructions

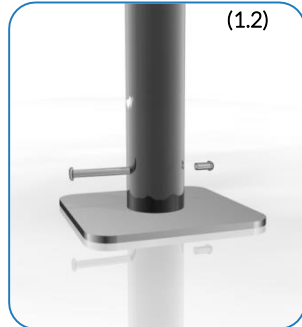

Weight of heaviest part 7.5kg

1. Instrument will arrive on site fully assembled. **(1.1)**
(See Assembly Guide)

2. Attach Surface Fixing posts to legs **(1.2)** (See Surface Fix Post Installation Sheet)

3. **Locate Plate** in desired location and mark holes to fix to desired surface.

4. Fix to Surface using recommended ground anchors not supplied

5. Make sure all fixings are covered and secure using cover caps provided

6. Attach the 1 of the beaters to each of the saddle strap on the hex frame. **(1.3)**

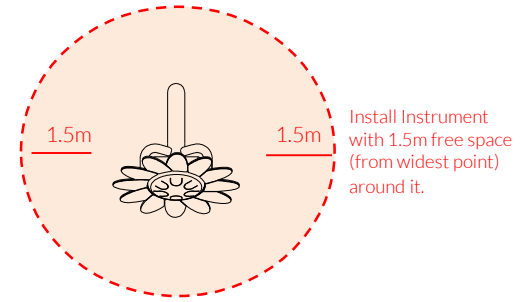

Install Instrument with 1.5m free space (from widest point) around it.

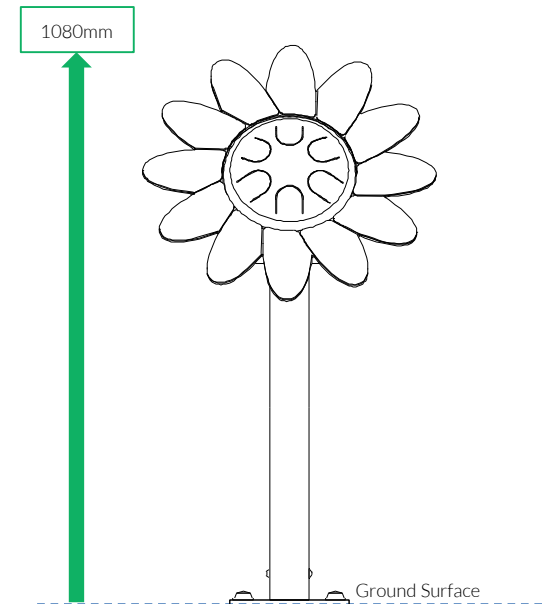

1080mm

Ground Surface

Surface Fixed Petal Drum Page 1 of 3



Instrument Components:

 x4
M6x20 Security Screw

 x2
M6 Saddle Strap

Metric Conversion:
1080mm/ 42.5"
1.5m/ 59"



Pair Small Red Beaters X1

Surface Fix Components:

 x1
M10x70 Security Screw

 x1
M10 Barrel Nut



Spares available from
www.musical-play.com or from
your local distributor

17 Kg

Assembly Guide PPPETA



Tools:

 x1
 x2
 TX 30 Driver Bit TX 45 Driver Bit





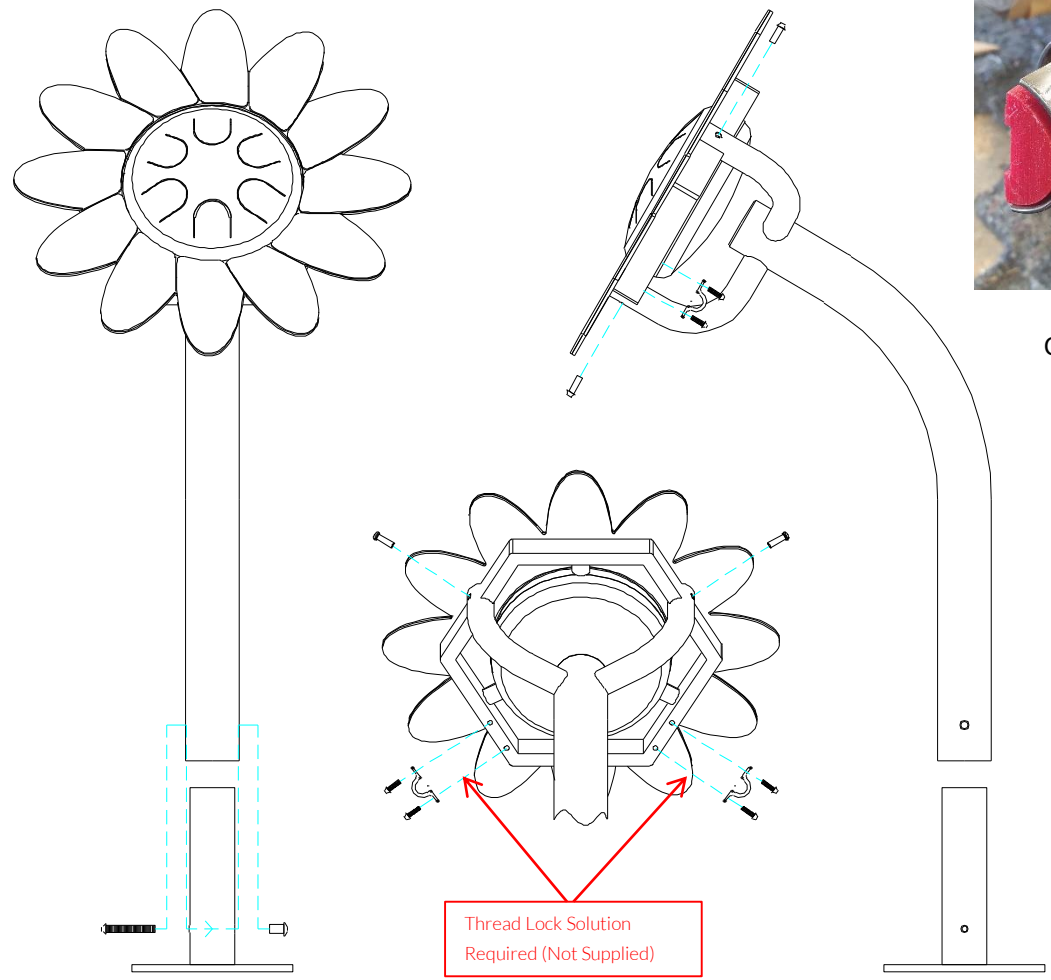

Install 3X PU Inserts into each arm before installing petal section



Surface Fixed
Petal Drum
Page 2 of 3



COMPONENTS LIST:

-  2 Part Cover Cap X8
-  M8X25 Pin trox X3
-  Saddle Strap X2
-  M6x20 Pin torx X4
-  M10x70 Pin torx X1
-  M10 Barrel Nut Pin torx X1



Instrument Components:

-  x4
M6x20 Security Screw
-  x2
M6 Saddle Strap

Thread Lock Solution
Required (Not Supplied)

 Pair Small Black Beaters X1

Surface Fix Components:

-  x1
-  x1

Spares available from
www.musical-play.com or from
your local distributor

17 Kg

Surface Fix Post Installation



Components:



x1

M10 Barrel Nut



x1

M10x70 Security Screw

Thread Lock Solution
Required (Not Supplied)

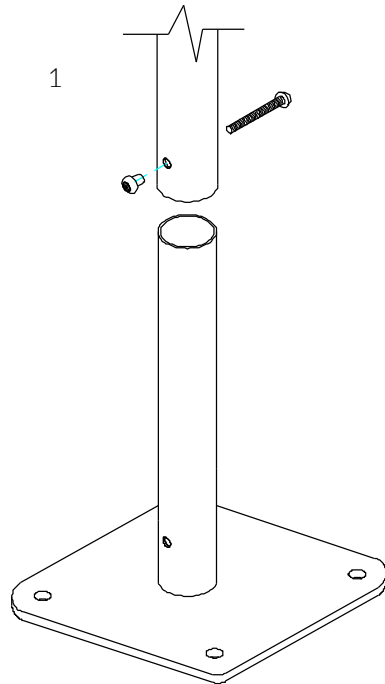

Locate the Surface fix Plate into the leg of the instrument.

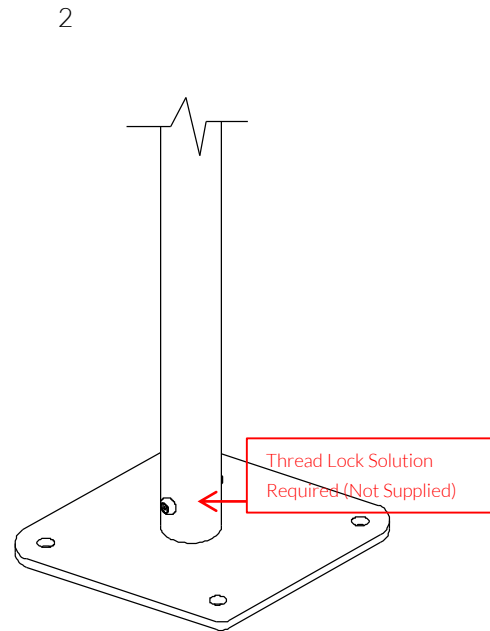

Fix instrument to Surface fix plate using M10 bolt and Barrel Nut and use **thread locking solution** to prevent fixings working loose.

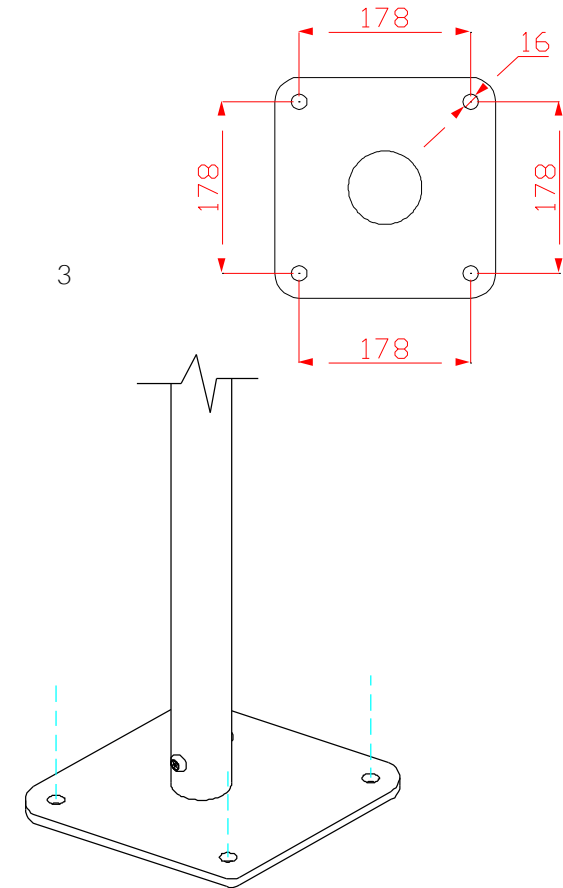

Fix Surface Plate to the ground surface **Ground Anchors Not provided** cover fixings with caps provided