

# Installation Instructions

## Surface Fixed

Sansa Rimba  
Page 1 of 3

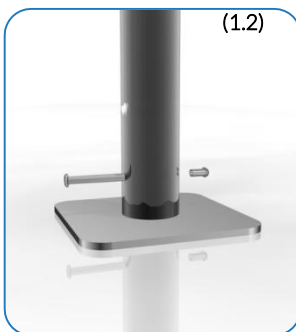
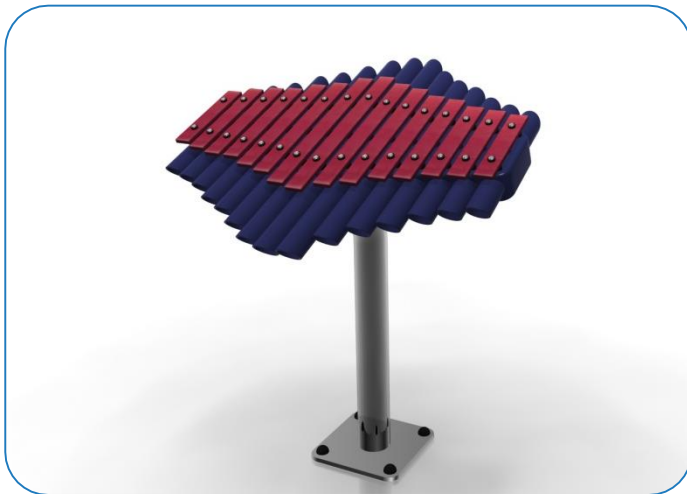
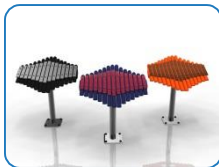

Weight of heaviest part **10.5kg** (Sansa Rimba)

1. Attach the steel legs to the base of the instrument with the M8 Nyloc Nuts and 2 part security caps. **(1.1)** (See Assembly Guide)

2. Attach Surface Fixing posts to legs **(1.2)** (See Ground Fix Post Installation Sheet)

3. **Locate Plate** in desired location and mark holes to fix to desired surface.

4. Fix to Surface using recommended ground anchors not supplied

5. Make sure all fixings are covered and secure using cover caps provided

6. Attach the 1 pair of beater to the saddle strap on the leg. **(1.3)**

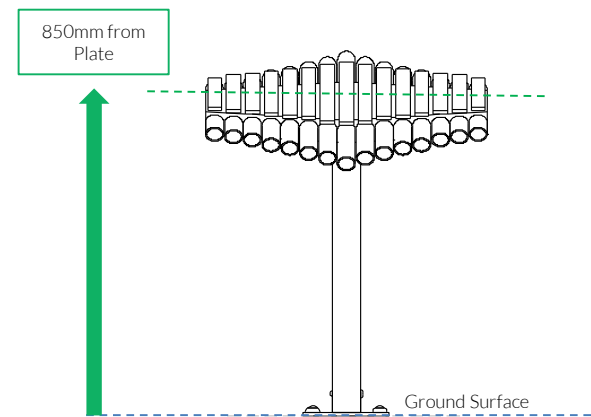
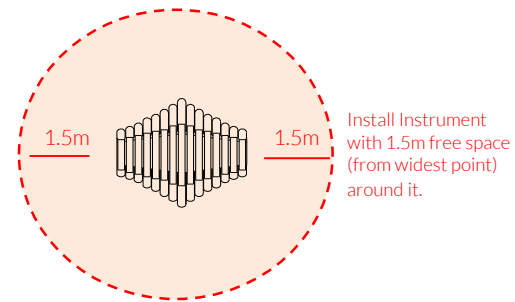

### Instrument Components:

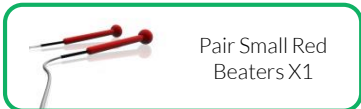

-  x4  
M8 Nyloc Nut
-  x2  
M6x20 Security Screw
-  x4  
2 Part Cover Cap
-  x1  
M6 Saddle Strap

Metric Conversion:  
250mm/ 10"  
300mm/ 12"  
450mm/ 18"  
700mm/ 28"  
850mm/ 33"  
1.5m/ 59"



Pair Small Red Beaters X1

### Surface Fix Components:

-  x1
-  x1
-  x4

Ground Anchors not supplied



Spares available from  
[www.musical-play.com](http://www.musical-play.com) or  
from your local distributor

14 Kg

# Assembly Guide PPSANS



Tools:

 x1
  x1

## Surface Fixed

Sansa Rimba  
Page 2 of 3

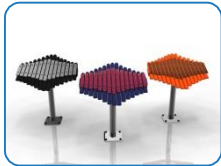





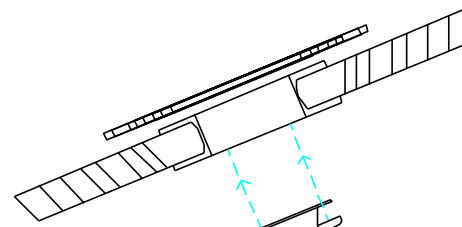
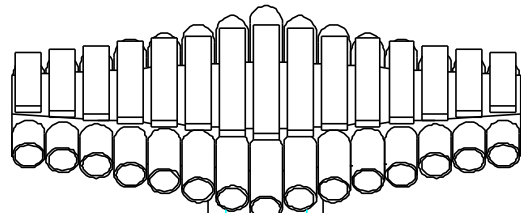



### Instrument Components:

-  x4  
M8 Nyloc Nut
-  x2  
M6x20 Security Screw
-  x4  
2 Part Cover Cap
-  x1  
M6 Saddle Strap



Thread Lock Solution  
Required (Not Supplied)

### COMPONENTS LIST:

-  2 Part Cover Cap X8
-  M8 Nyloc nut X4
-  M10 Nut X4
-  M10x200 Threaded Bar X2
-  Saddle Strap X1
-  M6x20 Pin torx X2
-  M10x70 Pin torx X1
-  M10 Barrel Nut Pin torx X1

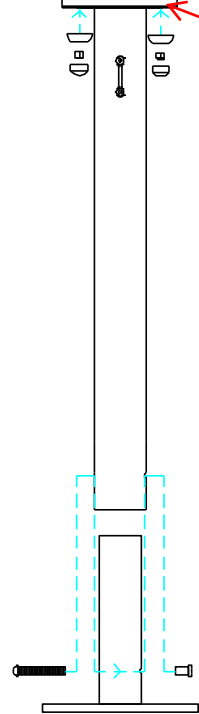

PPSANS FRONT

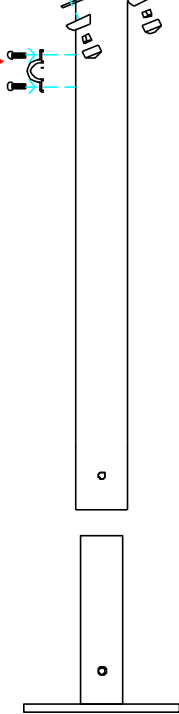

PPSANS SIDE

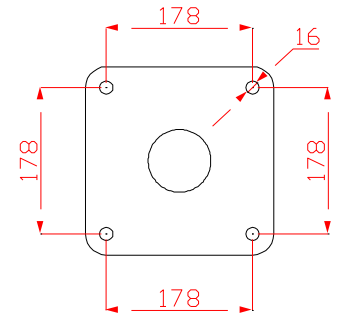



Thread Lock Solution  
Required (Not Supplied)



Pair Small Red Beaters X1

### Surface Fix Components:

-  x1
-  x1
-  x4

Ground Anchors  
not supplied

Spares available from  
[www.musical-play.com](http://www.musical-play.com) or  
from your local distributor

19.5Kg

# Surface Fix Post Installation

Tools:

 x2  
TX 45 Driver Bit

## Surface Fixed

Sansa Rimba  
Page 3 of 3

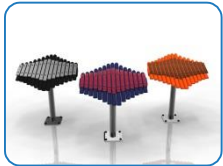

### Components:



x1

M10 Barrel Nut



x1

M10x70 Security Screw



x4

2 Part Cover Cap

Thread Lock Solution  
Required (Not Supplied)

Metric  
Conversion:  
50mm/ 2"  
250mm/ 10"  
350mm/ 14"  
400mm/ 16"  
450mm/ 18"

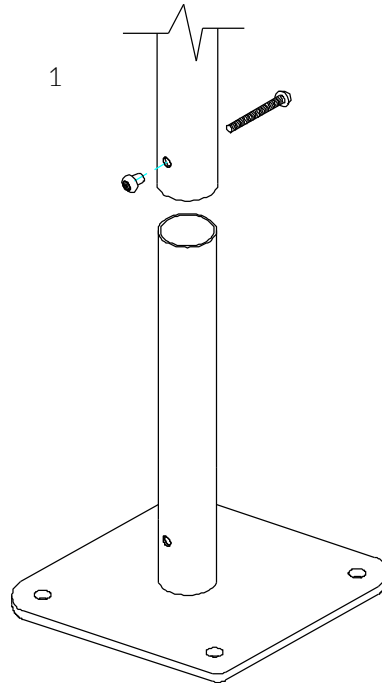

Locate the Surface fix Plate into the leg of the instrument.

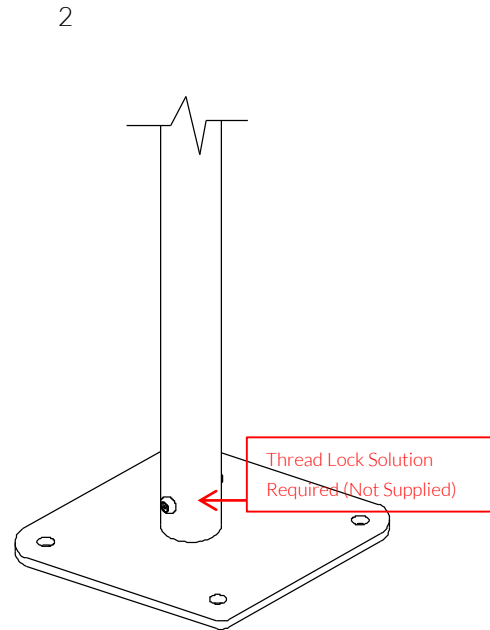

Fix instrument to Surface fix plate using M10 bolt and Barrel Nut and use **thread locking solution** to prevent fixings working loose.

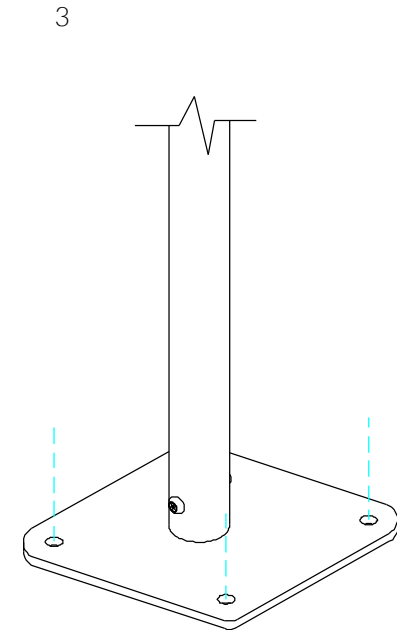

Fix Surface Plate to the ground surface **Ground Anchors Not provided** cover fixings with caps provided

Repeat Parts 1-3 for both legs