

Installation Instructions



1. Handpipes will arrive on site assembled, Ground Fixings will need to be installed **(1.1)** (See Assembly Guide)

2. Attach Ground Fixing posts to legs (See Ground Fix Post Installation Sheet)

3. Excavate **2** holes for the Steel legs **250mm diameter** by **400mm deep** in desired location upon decision from customer.

4. Locate (lower) legs into holes making sure they are vertical and level prior to concreting in place.

5. Once happy with location of the Instrument, **fill** holes using rapid hardening **concrete**. Be sure to compact concrete around legs and leave to dry according to manufactures guidelines.

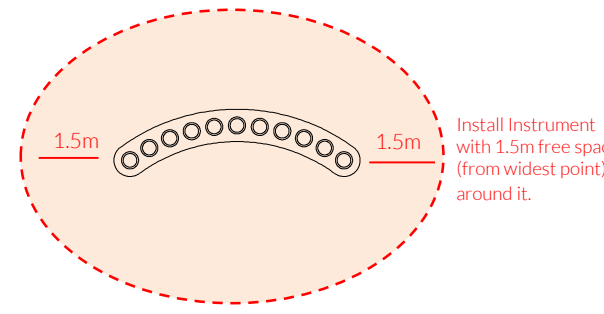

Ground Fixed

Handpipes
Page 1 of 3



Instrument Components:

Instrument assembled

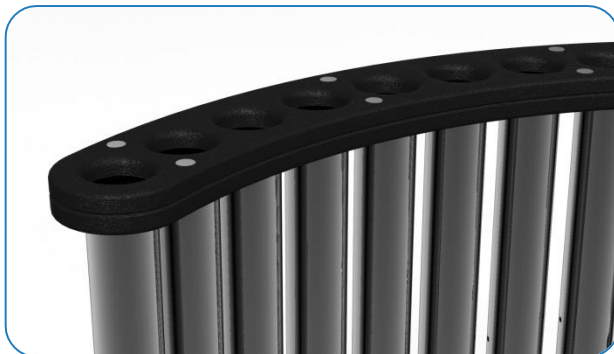

Weight of heaviest part **20kg** (Handpipes)

Metric Conversion:
250mm/ 10"
400mm/ 16"
905mm/ 35"
1.5m/ 59"

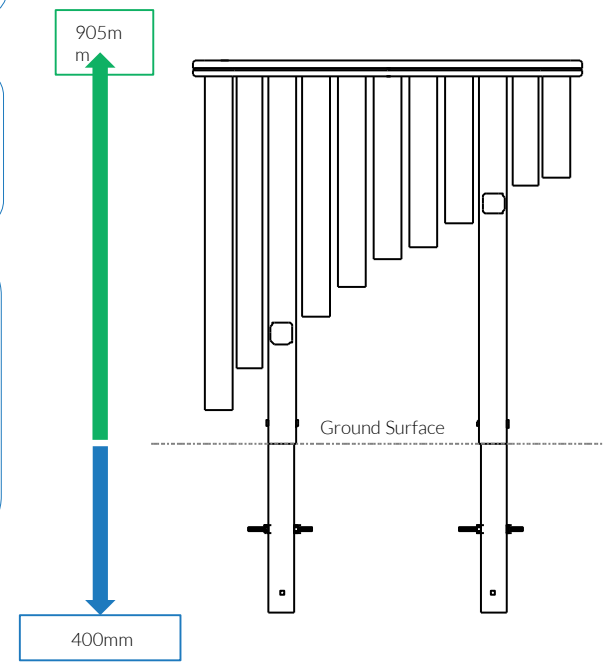

Ground Fix Components:

-  x4
-  x8
-  x2
-  x2

Spares available from www.musical-play.com or from your local distributor

25 Kg

Assembly Guide PPHAND



Ground Fixed

Handpipes
Page 2 of 3





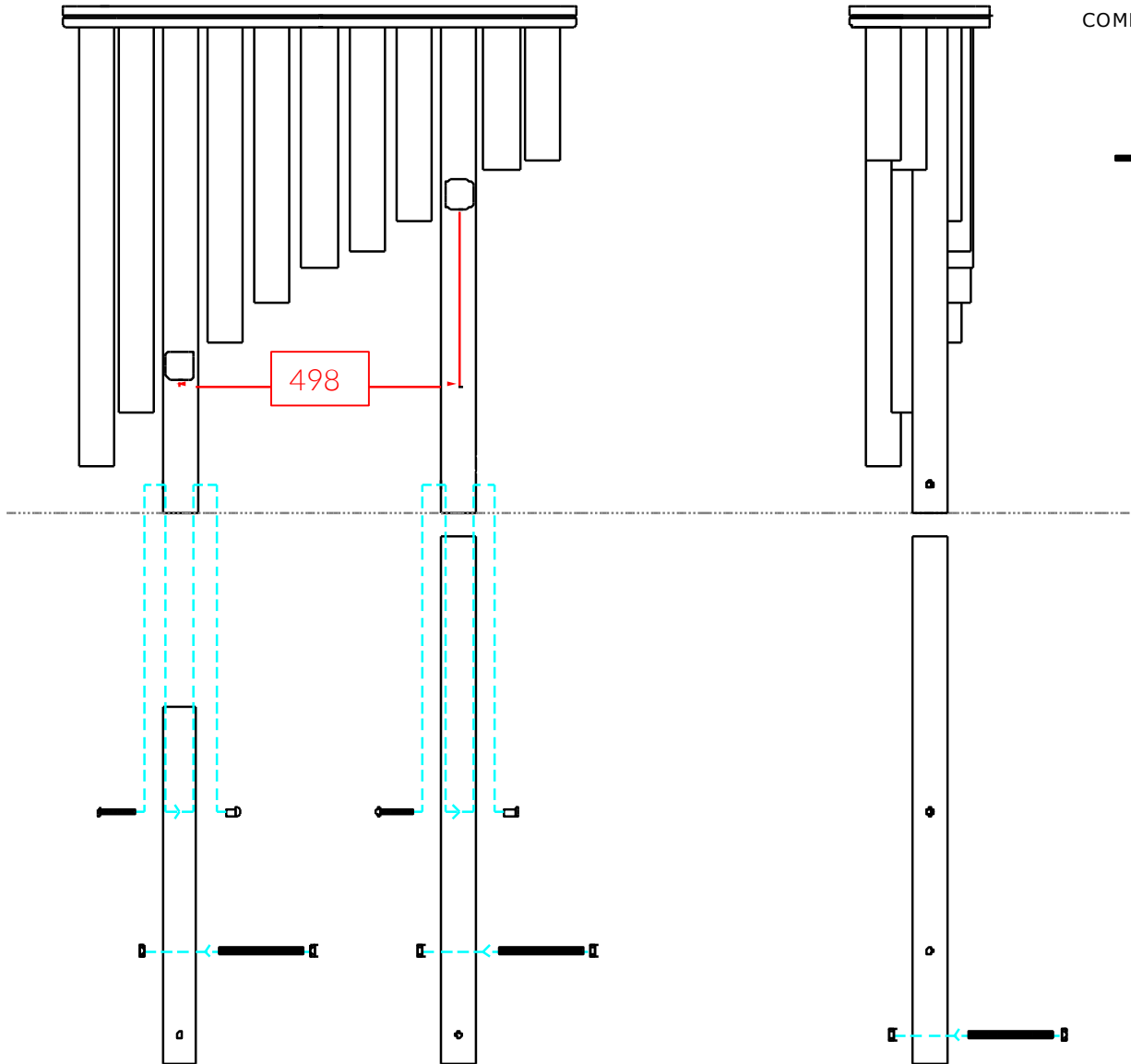

Instrument
Components:

Instrument assembled

Thread Lock Solution
Required (Not Supplied)



COMPONENTS LIST:

-  M10 Nut X8
-  M10x200 Threaded Bar X4
-  M10x60mm Security Screw X2
-  M10 Barrel Nut X2



Ground Fix
Components:

-  x4
M10x200 Bolt
-  x8
M10 Nut
-  x2
M10x60 Security Screw
-  x2
M10 Barrel Nut

Spares available from
www.musical-play.com or
from your local distributor

25 Kg

Ground Fix Post Installation

Tools:
 x2
 TX 45 Driver Bit

Foundations should not present a hazard. These foundations are recommended as a guide, for more information on foundation details for various surface see Part 7 of BS EN 1176.



Ground Fixed

Handpipes
 Page 3 of 3

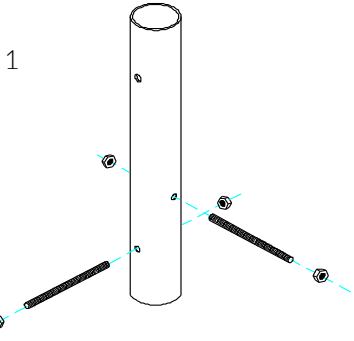

1 Insert M10x 200 Threaded bar into pre drilled holes in Ground Fixing Post

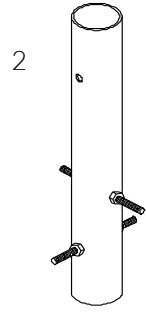

2 Fix M10x 200 Threaded bar in place using M10 Nuts

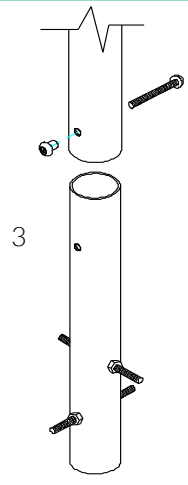

3 Locate the Ground fix Post into the leg of the instrument.

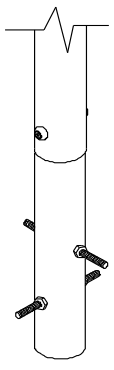

4 Fix instrument to Ground fix post using M10 bolt and Barrel Nut and use **thread locking solution** to prevent fixings working loose.

Components:

-  x4
- M10x200 Bolt
-  x8
- M10 Nut
-  x2
- M10 Barrel Nut
-  x2
- M10x60 Security Screw

Metric Conversion:
 50mm/ 2"
 250mm/ 10"
 350mm/ 14"
 400mm/ 16"
 450mm/ 18"

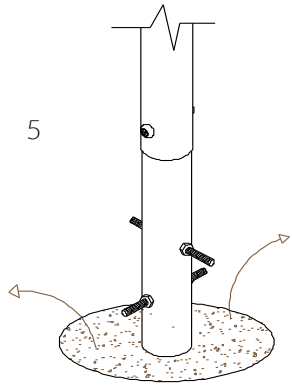

5 Excavate 6 holes with a 250mm diameter tapering down to 350mm diameter and 450mm depth

400mm min depth

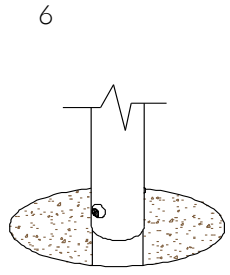

6 Compact base of hole with 50mm of aggregate. Lower ground Fix post attached to instrument into hole (check instrument straight and level before filling with concrete)

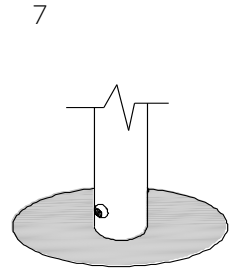

7 Fill hole with fast drying concrete to manufacturers specifications.

Repeat points 1-7. Handpipes requires 2 Ground Fix Posts

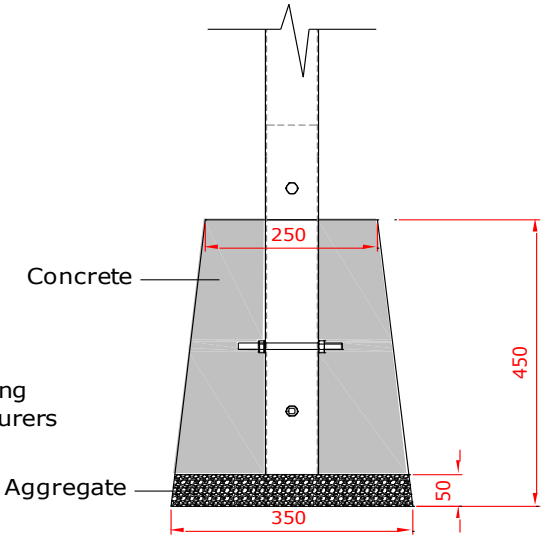

Installation Instructions



Ground Fixed

Emperor Chimes
Page 1 of 2

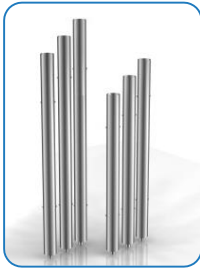

Instrument Components:

Emperor Chimes are pre-assembled

Metric Conversion:
100mm/ 4"
250mm/ 10"
600mm/ 24"
1.5m/ 59"
1785mm/ 70"
2490mm/ 98"

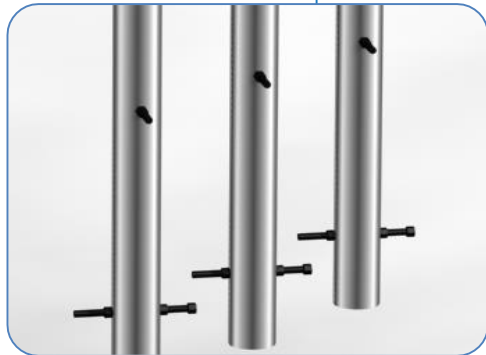
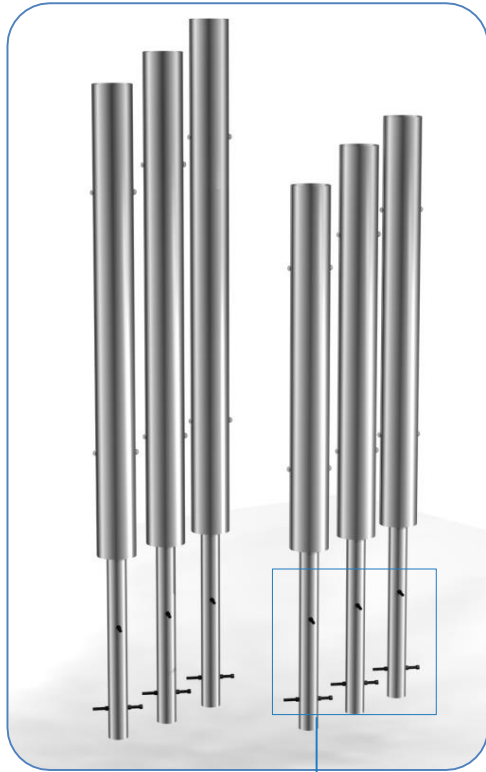

Weight of heaviest part 25kg (XL Chime)

1. Attach Ground Fixing posts to legs (1.2) (See Ground Fix Post Installation Sheet)

2. Excavate 6 holes for Emperor chimes 250mm diameter by 600mm deep in desired location upon decision from customer.

3. Locate (lower) legs into holes making sure they are vertical and level prior to concreting in place. Chimes should be 100mm from ground surface.

4. Once happy with location of the chimes, fill holes using rapid hardening concrete. Be sure to compact concrete around legs and leave to dry according to manufactures guidelines.

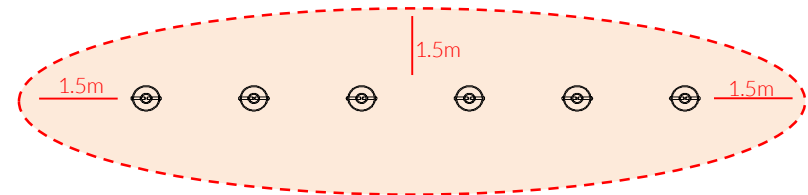

Install Instrument with 1.5m free space (from widest point) around it.

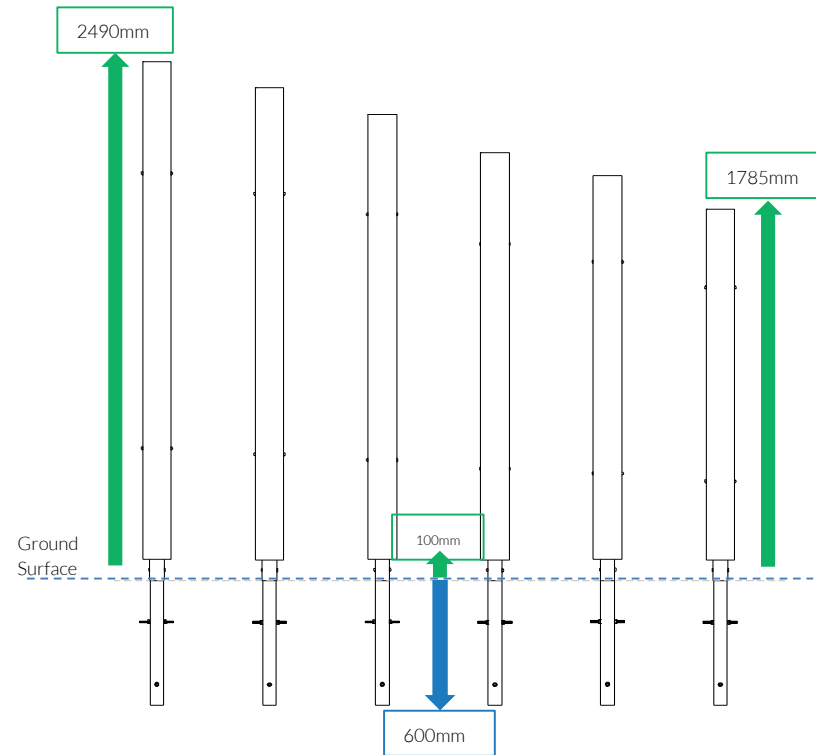

Ground Fix Components:

-  x12
-  x24
-  x6
-  x6

Spares available from www.musical-play.com or from your local distributor

117 Kg

Ground Fix Post Installation

Foundations should not present a hazard. These foundations are recommended as a guide, for more information on foundation details for various surface see Part 7 of BS EN 1176.

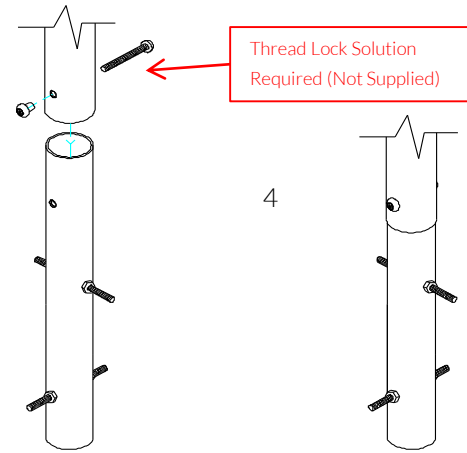

Tools:

x2
TX 45 Driver Bit

Metric Conversion:
50mm/2"
100mm/4"
250mm/10"
350mm/14"
600mm/24"
650mm/26"

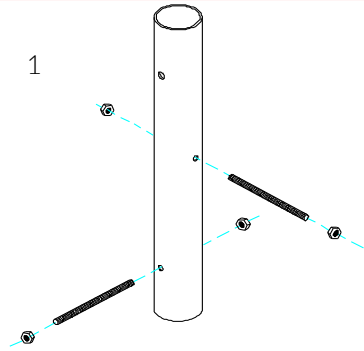

1
Insert M10x 150 Threaded bar into pre drilled holes in Ground Fixing Post

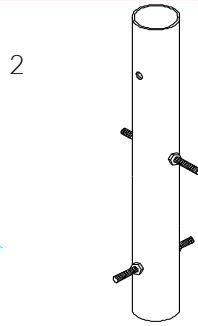

2
Fix M10x 150 Threaded bar in place using M10 Nuts

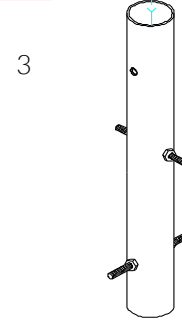

3
Locate the Ground fix Post into the leg of the instrument.

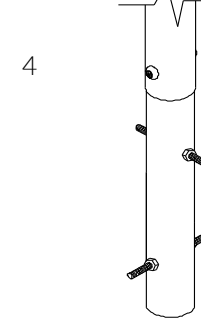

4
Fix instrument to Ground fix post using M10 bolt and Barrel Nut and use **thread locking solution** to prevent fixings working loose.

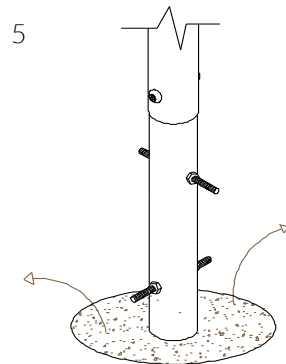

5
Excavate 6 holes with a 250mm diameter tapering down to 350mm diameter and 650mm depth

600mm max depth

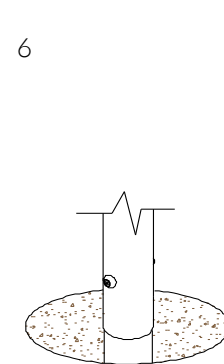

6
Compact base of hole with 50mm of aggregate. Lower ground Fix post attached to instrument into hole (check instrument straight and level before filling with concrete)

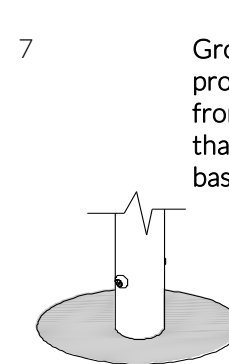

7
Fix hole with fast drying concrete to manufacturers specifications.

Ground fix tube protrudes 300mm from ground surface that inserts into the base of the chime post

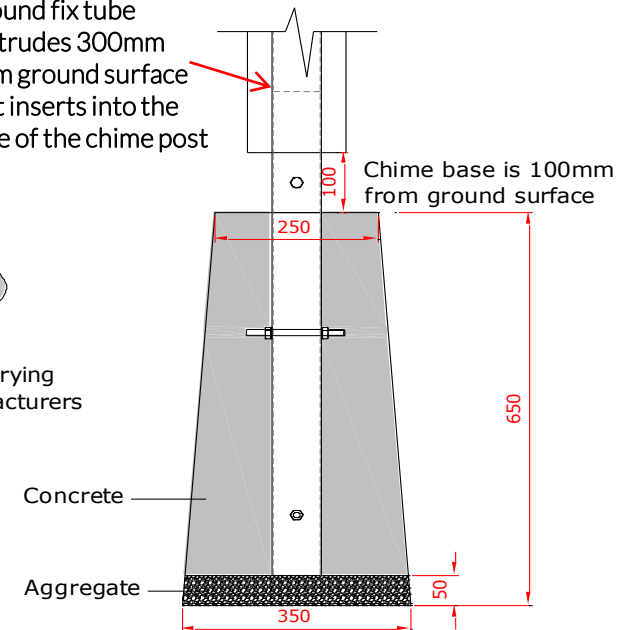

Concrete

Aggregate

650

Chime base is 100mm from ground surface

250

350

50

100

Ground Fixed

Emperor Chimes
Page 2 of 2

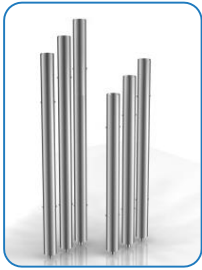

Components:



x12

M10x150 Threaded Bar



x24

M10 BZP Nut



x6

M10 Barrel Nut



x6

M10x50 Security Screw

Thread Lock Solution
Required (Not Supplied)

Installation Instructions

Ground Fixed

Cajón
Page 1 of 3



Instrument Components:



x8

M8x25mm Pin Torx

Metric Conversion:
200mm/ 8"
400mm/ 16"
450mm/ 18"
1.5m/ 59"



1. Using **M10 nuts and 200mm bolts** supplied locate through pre drilled holes and secure bolts in place to support in ground pole in concrete. (See Assembly Guide)



2. **Attach Cajón** to ground fix plate and leg using **M8x25mm security screws** provided using thread lock solution not supplied.



3. **Excavate a hole** for the drum **200mm diameter by 450 deep** in desired location upon decision from customer. (See Ground Fix Post Installation)

4. Locate (lower) leg into hole making sure that the cajón is level on ground surface.

5. Once happy with location of the Drum, **fill** hole using rapid hardening **concrete**. Be sure to compact concrete around legs and leave to dry according to manufactures guidelines.

Weight of heaviest part **18kg** (Cajon Drum)

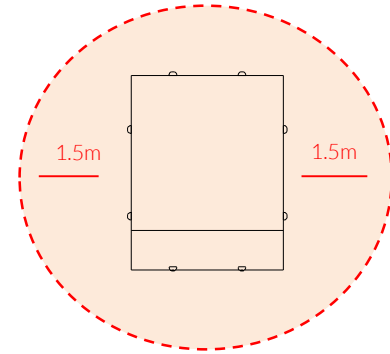

Install Instrument with 1.5m free space (from widest point) around it.

CAUTION: Drum surface can get hot in direct sunlight, if possible install in shaded areas.

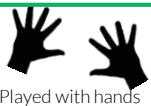
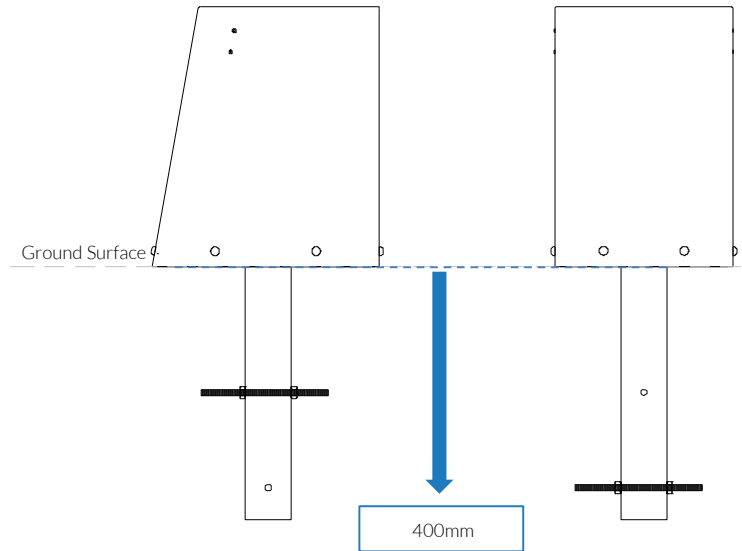

Played with hands

Ground Fix Components:



x2

M10x150 Threaded bar



x4

M10BZP Nut

Spares available from www.musical-play.com or from your local distributor

22 Kg

Assembly Guide Cajón



Ground Fixed

Cajón
Page 2 of 3



Instrument Components:



x8

M8x25mm Pin Torx

CAUTION: Drum surface can get hot in direct sunlight, if possible install in shaded areas.

Thread Lock Solution Required (Not Supplied)

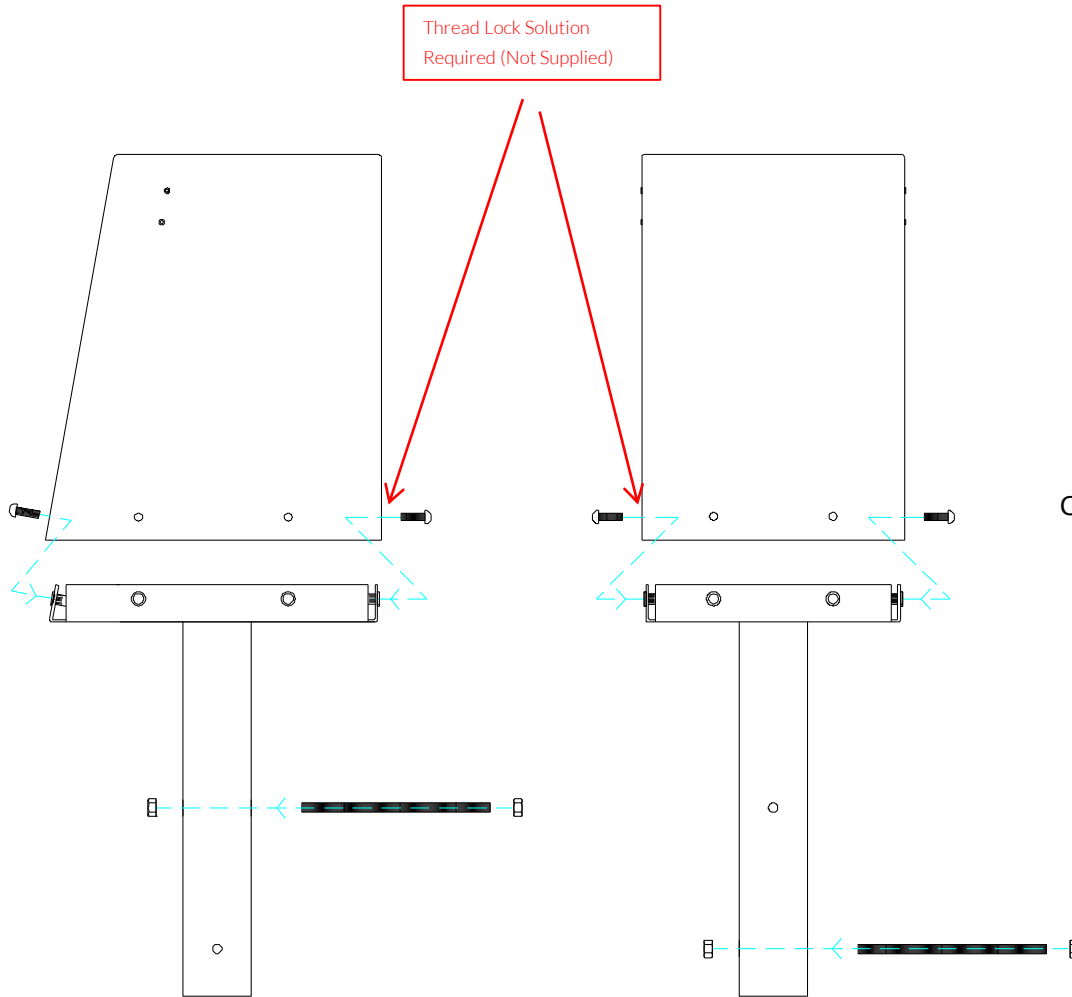

COMPONENTS LIST:

 M10 Nut X4

 M10x200 Threaded Bar X2

 M8x25 Pin torx X8



Played with hands

Ground Fix Components:



x2

M10x150 Threaded bar



x4

M10BZP Nut

Spares available from
www.musical-play.com or
from your local distributor

22 Kg
13.4 Kg

Ground Fix Post Installation

Ground Fixed

Cajón
Page 3 of 3

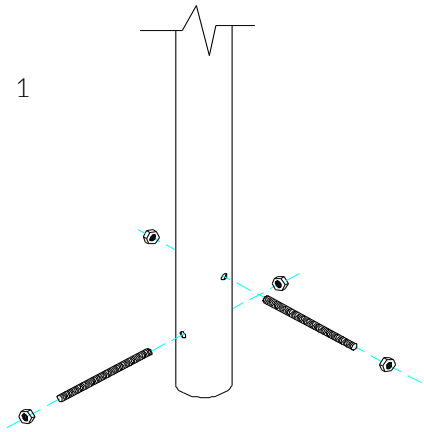

1
Insert M10x 200 Threaded bar into pre drilled holes in Ground Fixing Post

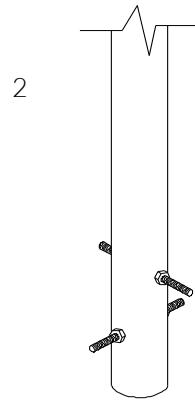

2
Fix M10x 200 Threaded bar in place using M10 Nuts

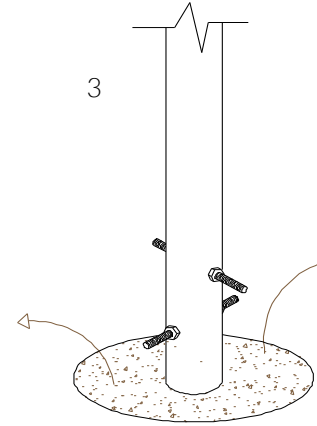

3
Excavate a hole with a 250mm diameter tapering down to 350mm diameter and 450mm depth

Foundations should not present a hazard. These foundations are recommended as a guide, for more information on foundation details for various surface see Part 7 of BS EN 1176.

4

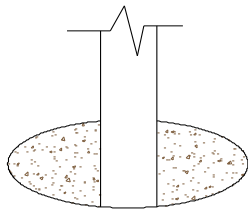

4
Compact base of hole with 50mm of aggregate. Lower ground Fix post attached of instrument into hole (check instrument straight and level before filling with concrete)

5

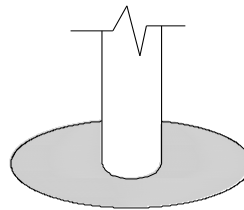

5
Fill hole with fast drying concrete to manufacturers specifications.

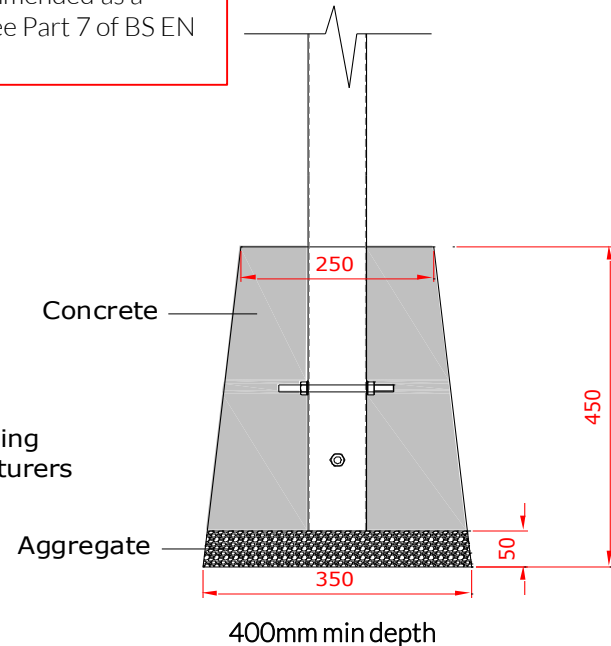

Components:



Metric Conversion:
50mm/ 2"
250mm/ 10"
350mm/ 14"
400mm/ 16"
450mm/ 18"

Thread Lock Solution
Required (Not Supplied)

Installation Instructions

Ground Fixed

Babel Drum
Page 1 of 3



Instrument Components:



Metric Conversion:
200mm/ 8"
400mm/ 16"
530mm/ 20 55/64"
680mm/ 26 49/64"
700mm/ 27 9/16"
850mm/ 33 15/32"
980mm/ 38 37/64"
1.5m/ 59"

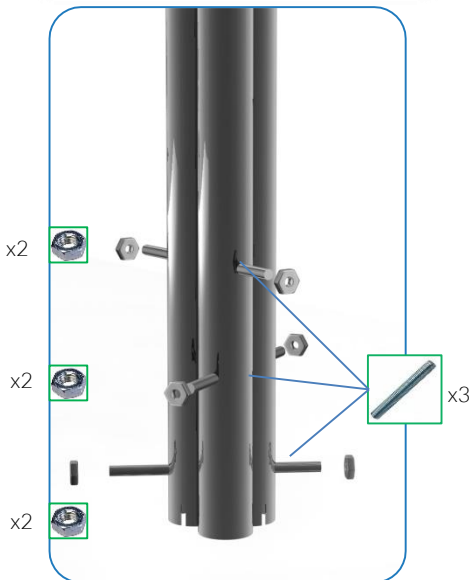

Weight of heaviest part **17.5kg** (Large Babel Drum)
Weight of heaviest part **13.4kg** (Small Babel Drum)

1. Unpack ground fixing legs 3no.

2. Lay packaging out on floor or assemble on non-abrasive surface to prevent marking of polished stainless steel.

3. Align holes on legs (opposite end to polished domes) and secure in place using 3no. M10 x 200mm threaded bar and 6no. M10 nuts provided
Tools required 2no. 17mm metric spanner/wrench (11/16 inch or alternatively using adjustable wrench)

4. Invert assembled frame so domed ends face upwards.

5. Place 8mm Hex Key supplied into hole in leg and lock into internal bolt.

6. Remove Black caps opposite side of leg and keeping Hex Key in place, slide black polyurethane damper over bolt until flush with end of bolt. Repeat for other 2 legs

7. Unpack babel drum leaving black film in place to protect.

8. Align holes in side of babel drum with bolts on legs.

9. Using 8mm Hex Key screw bolts into drum to secure in place.
Use thread locking solution
All hole locations are laser cut for accuracy to ensure holes in drum align perfectly with legs.

10. Using TX40 driver provided secure M8 x 25mm security bolts into external holes in legs 3no. Use thread lock solution

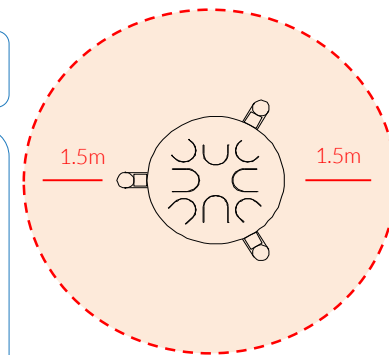

Install Instrument with 1.5m free space (from widest point) around it.

CAUTION: Drum surface can get hot in direct sunlight, if possible install in shaded areas.

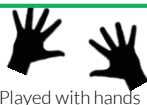
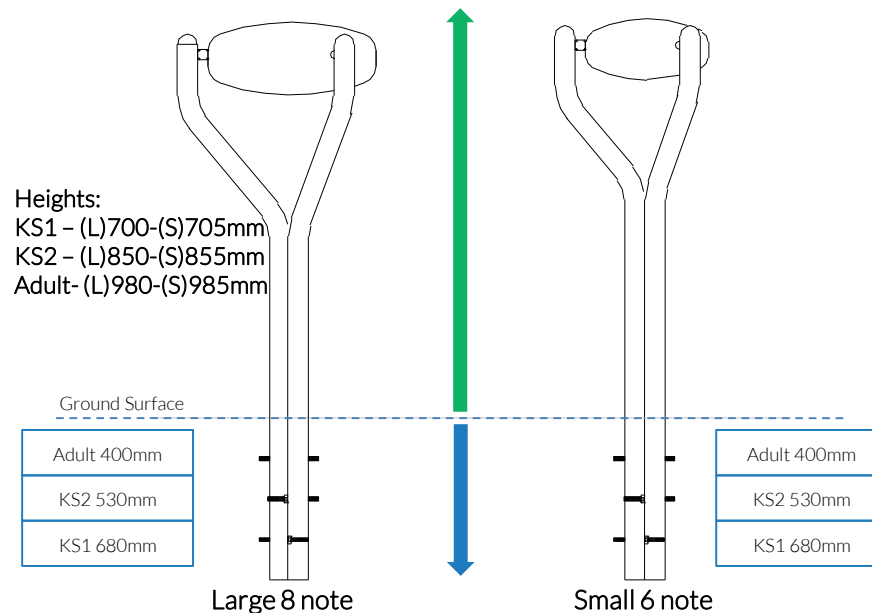

Ground Fix Components:

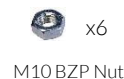

Spares available from www.musical-play.com or from your local distributor

22 Kg
13.4 Kg

Assembly Guide PPBDL-S

Tools:

Hex T Key x1
TX 40 Driver Bit x1

Ground Fixed

Babel Drum
Page 2 of 3



Instrument Components:

x3
M8x25mm Pin Torx

Thread Lock Solution
Required

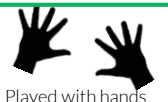
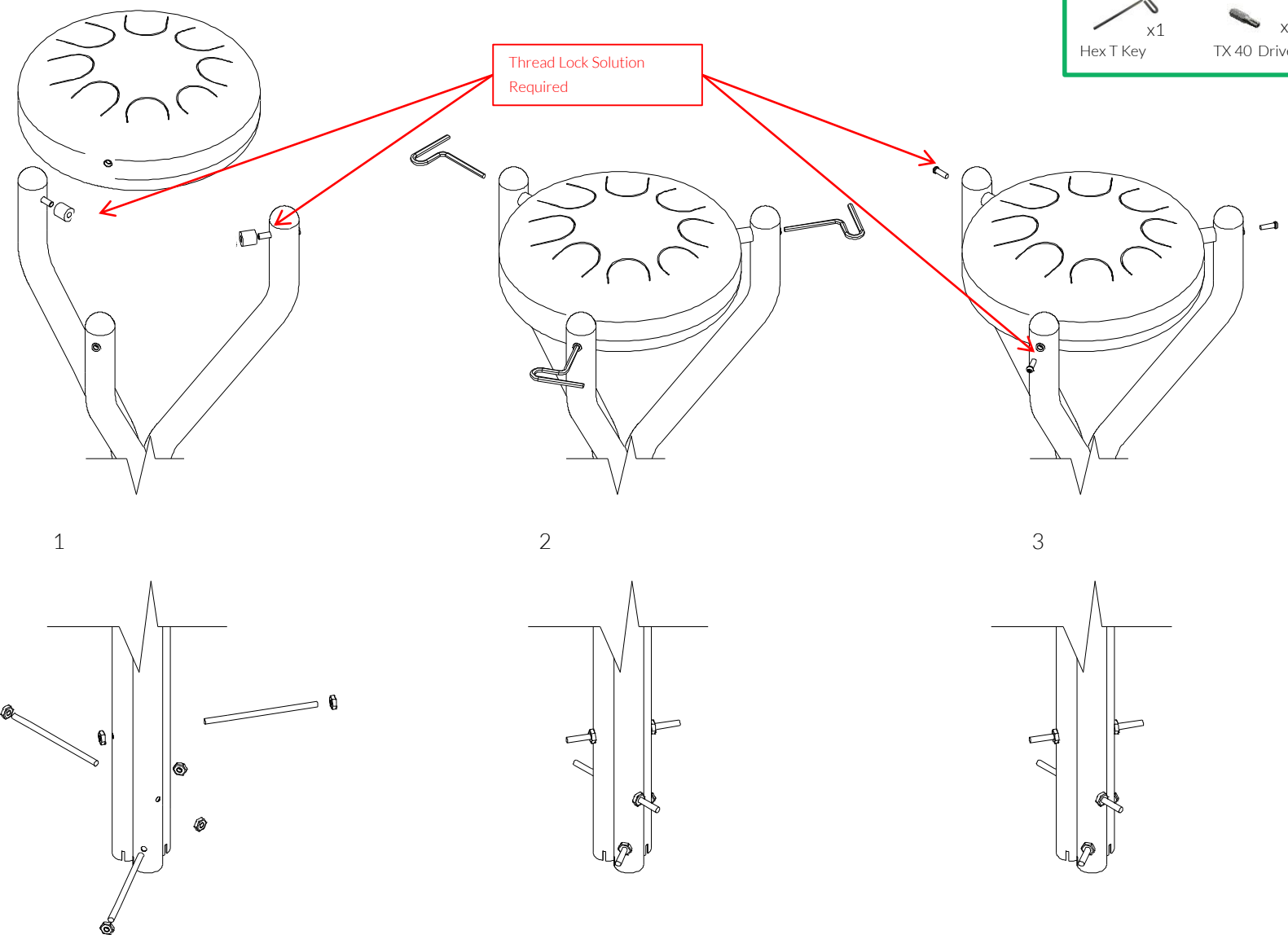

Ground Fix Components:

x3
M10x200 Threaded bar

x6
M10 BZP Nut

Spares available from
www.musical-play.com or
from your local distributor

22 Kg
13.4 Kg

Ground Fix Installation

1 Insert M10x 200 Threaded bar into pre drilled holes in Frame of Babel Drum using M10 BZP Nuts

2 Excavate a holes with a 250mm diameter tapering down to 350mm diameter and 450mm depth

3 Compact base of hole with 50mm of aggregate. Lower ground Fix post attached to instrument into hole (check instrument straight and level before filling with concrete)

4 Fill hole with fast drying concrete to manufacturers specifications.

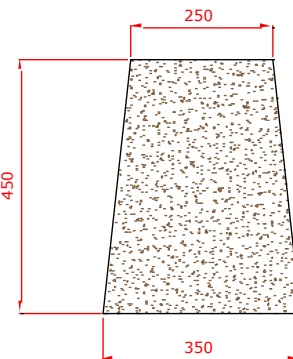
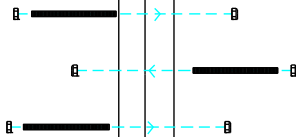
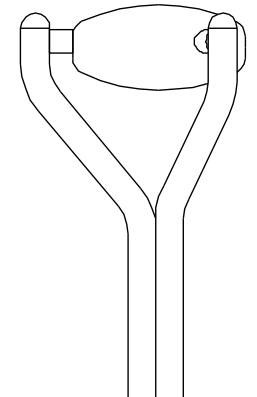
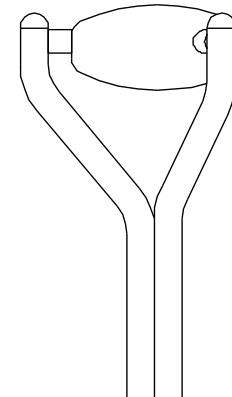
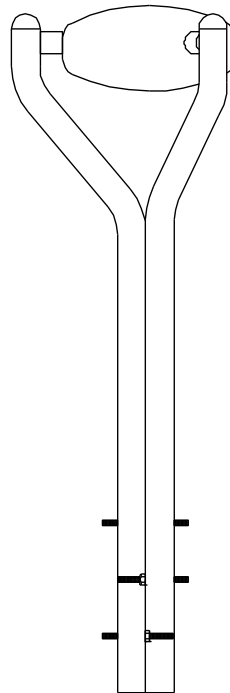
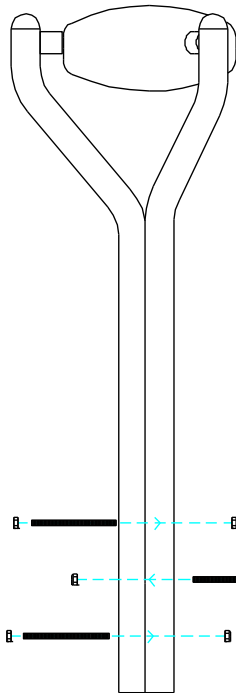

If Drum needs to be positioned lower a deeper hole can be excavated.

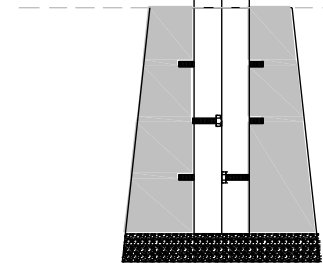
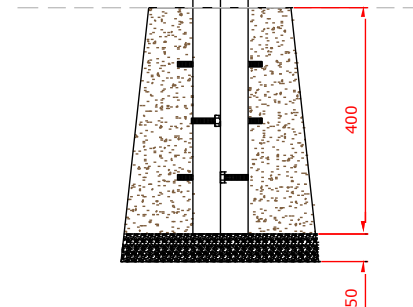

Foundations should not present a hazard. These foundations are recommended as a guide, for more information on foundation details for various surface see Part 7 of BS EN 1176.

Ground Fixed

Babel Drum
Page 3 of 3



Components:



x3

M10x200 Threaded Bar



x6

M10 BZP Nut

Metric Conversion:

50mm/ 2"
250mm/ 10"
350mm/ 14"
400mm/ 16"
450mm/ 18"