

# Installation Instructions

## Ground Fixed

Tumbadoras  
Page 1 of 3

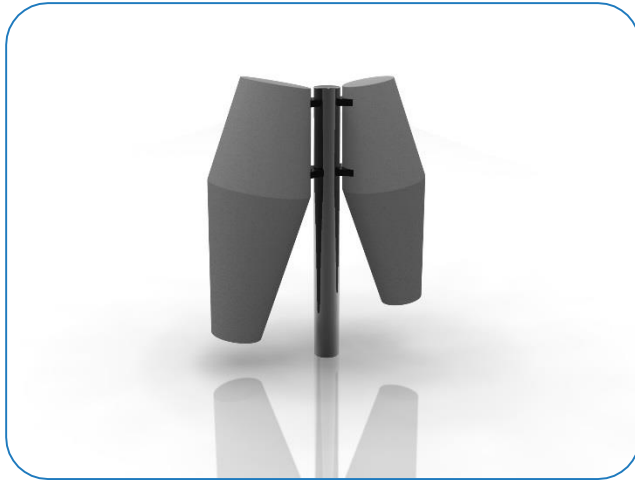

1. Attach the steel leg to each of the congas with the M10x50 security screws, square washers and PU mounts. (1.1) (See Assembly Guide)

2. Attach Ground Fixings to legs (1.2) (See Ground Fix Post Installation Sheet)

3. Excavate 1 hole for the Steel leg 250mm diameter by 300mm deep, in desired location upon decision from customer.

4. Locate (lower) legs into hole making sure they are vertical and level prior to concreting in place.

5. Once happy with location of the Instrument, fill hole using rapid hardening concrete. Be sure to compact concrete around legs and leave to dry according to manufactures guidelines.

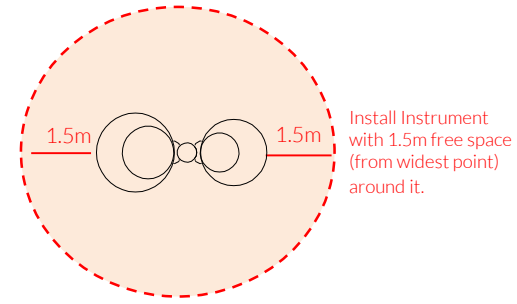



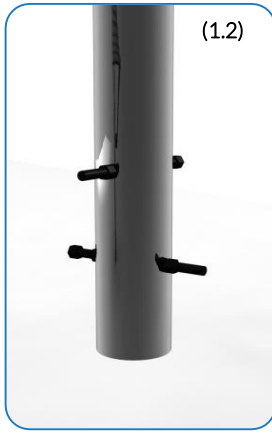
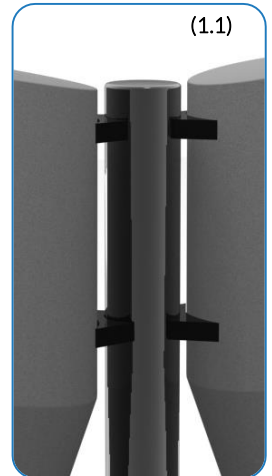
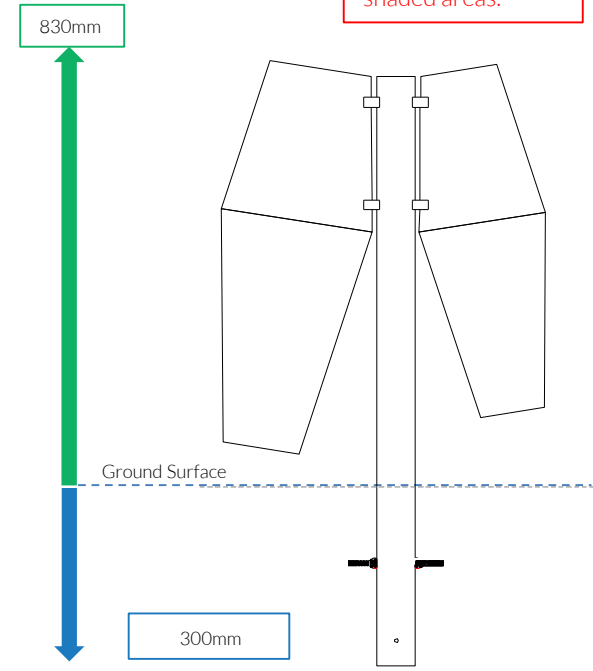

**CAUTION:** Drum surface can get hot in direct sunlight, if possible install in shaded areas.



Weight of heaviest part 16kg (Large Djembe Drum)

### Instrument Components:

-  x4
- M10x50 Security Screw
-  x4
- M10x50x3 Square washer
-  x2
- PU 200 Mount
-  x2
- PU 250 Mount

Metric Conversion:  
250mm/ 10"  
400mm/ 16"  
850mm/ 33"  
1.5m/ 59"



### Ground Fix Components:

-  x2
- M10x200 Bolt
-  x4
- M10 Nut

Spares available from  
[www.musical-play.com](http://www.musical-play.com) or  
from your local distributor

25 Kg

# Assembly Guide PPTUMB

Tools:

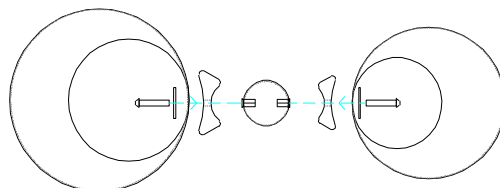



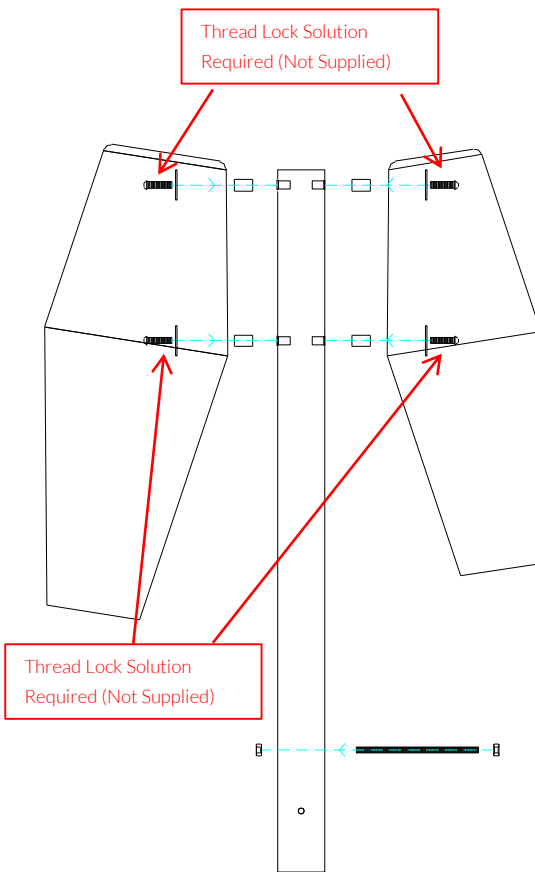

 x1  
 TX 45 Driver Bit

PPTUMB PLAN



PPTUMB FRONT

COMPONENTS LIST:

-  M10x50 Pin torx X4
-  M10x50x3 square washer X4
-  M10 Nut X4
-  M10x200 Threaded Bar X2
-  HDPE MOUNT 200 X2
-  HDPE MOUNT 250 X2

Ground Fixed

Tumbadoras  
Page 2 of 3



Instrument Components:



x4

M10x50 Security Screw



x4

M10x50x3 Square washer



x2

PU 200 Mount



x2



PU 250 Mount

Thread Lock Solution  
Required (Not Supplied)



Played with hands

Ground Fix  
Components:

-  x2
-  x4

Spares available from  
[www.musical-play.com](http://www.musical-play.com) or  
from your local distributor

15 Kg

# Ground Fix Post Installation

## Ground Fixed

Tumbadoras  
Page 3 of 3

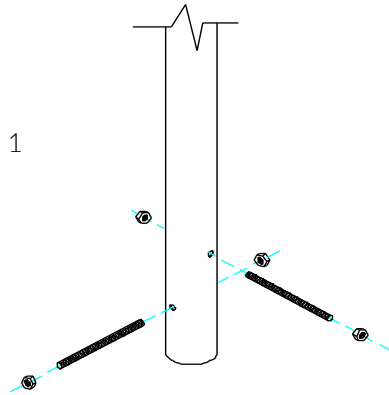

1  
Insert M10x 200 Threaded bar into pre drilled holes in Ground Fixing Post

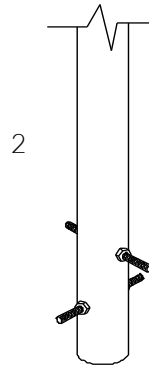

2  
Fix M10x 200 Threaded bar in place using M10 Nuts

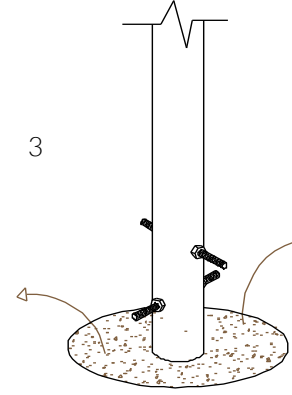

3  
Excavate a hole with a 250mm diameter tapering down to 350mm diameter and 350mm depth

Foundations should not present a hazard. These foundations are recommended as a guide, for more information on foundation details for various surface see Part 1 of BS EN 1176.

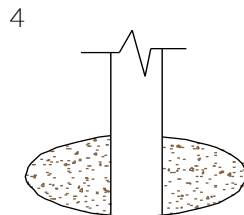

4  
Compact base of hole with 50mm of aggregate. Lower ground Fix post attached of instrument into hole (check instrument straight and level before filling with concrete)

300mm min depth

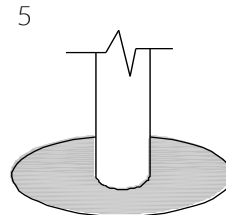

5  
Fill hole with fast drying concrete to manufacturers specifications.

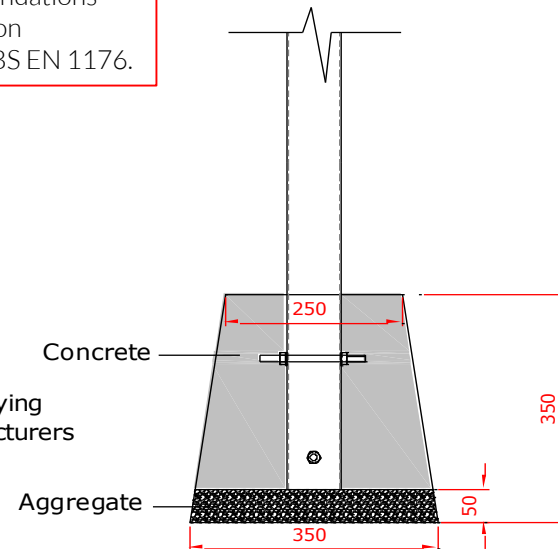

## Components:



x2

M10x200 Bolt



x4

Metric Conversion:  
50mm/ 2"  
250mm/ 10"  
350mm/ 14"